

0.36°/0.72° Stepping Motor and Driver Package CRK Series

● Additional Information ●
 Technical reference → Page G-1
 Safety standards → Page H-2

This series is a motor and driver package product that combines a high-performance, 0.36°/0.72° stepping motor with a compact and low-vibration microstep driver. The lineup consists of a Pulse Input Package or a Built-In Controller Package. Both packages are available with gearheads and encoder options. Built-In Controller Package with encoder is available with our self correction function.



● For detailed product safety standard information including standards, file number and certification body, please visit www.orientalmotor.com.



Features

● Compact, Lightweight Microstep Driver

The driver in the **CRK** Series achieves microstepping performance in a compact, lightweight body.

◇ Smooth Drive Function for Enhanced Ease of Use

The Smooth Drive Function automatically controls motion via microstepping at the same travel amount and speed used in the full-step mode, without requiring the operator to change the pulse input settings. This function is particularly useful when the system is operated in the full-step or half-step mode.

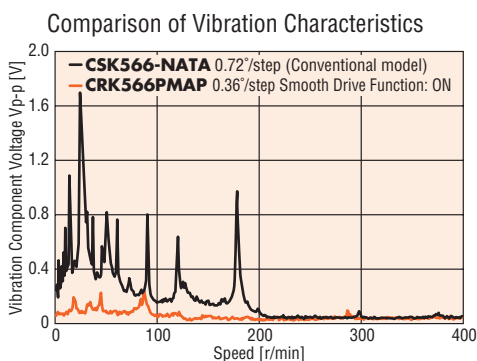
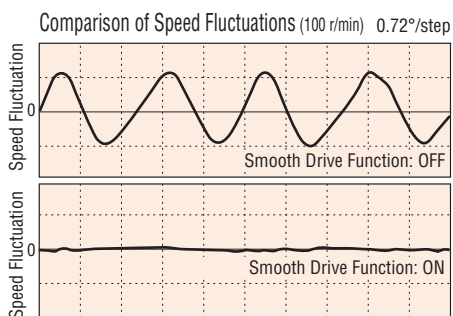

◇ Lower Vibration and Noise Achieved by Microstepping

The basic step angle of the motor can be divided into a maximum of 250 microstep angles without using any mechanical element such as a reduction gear. As a result, vibration and noise are further reduced.

● Two Driver Types are Available

Two types of drivers are available, a Pulse Input Package and a Built-In Controller Package, to suit the customer's control method.

◇ Pulse Input Package

The motor is controlled from a pulse generator (not supplied), and a compact and lightweight [40 g (0.09 lb.)] driver.

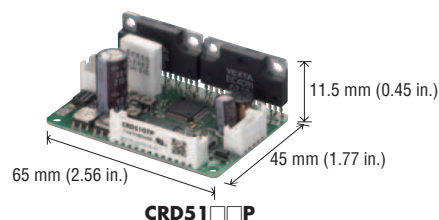

◇ Built-In Controller Package

The **CRK** Series with built-in controller is a compact, space saving stepping motor and driver package with a powerful, feature-rich controller built-in. The driver supports stand alone or RS-485 communications with multi-drop capability for network operation and I/O control.



Wide Variety of Motors

This series offers models ranging from the high-torque type and standard type, as well as various geared types. You can find a product meeting your specific torque, resolution or other needs from a wide range of specifications.

Step Angle 0.36° High-Torque Motor

Improved Stopping Accuracy

The positioning accuracy of a stepping motor is affected by the friction of the load.

The Step Angle 0.36° High-Torque type achieves high accuracy and reliability based on Oriental Motor's latest precision machining technology. The motor resolution is increased to double the level of a standard model to reduce the displacement angle against load torque, thereby achieve high positioning accuracy. Vibration is also reduced.

0.72°/Step
Standard type: 50 teeth
Resolution: 500 steps per rotation
= 0.72°/step



0.36°/Step
High Torque type: 100 teeth
Resolution: 1000 steps per rotation
= 0.36°/step

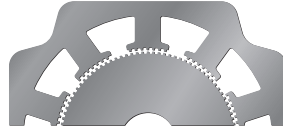

Resolution is increased!

Comparison of Angle – Torque Characteristics

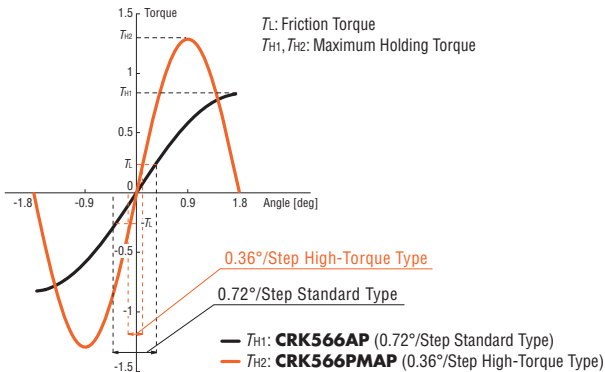

Stop Position Accuracy of 2 Arc Minutes (No load)

The Step Angle 0.36° High-Torque type is designed with a stop position accuracy of 2 arc minutes (0.034°) [standard type: 3 arc minutes (0.05°)]. The reduced error helps improve the positioning accuracy of your equipment.

Static Angle Characteristics

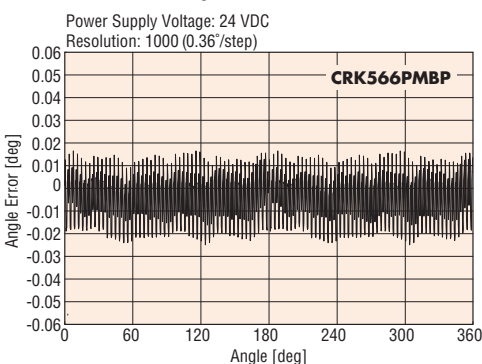

High-Torque Motor (Step Angle 0.36°, 0.72°)

The high-torque type adopts a newly designed high-torque motor that widens the range of applications.

- The smaller motor allows for compact equipment design.
- The motor current is reduced to suppress heat generation.

Example: Avoidance of temperature rise in precision equipment or machinery

Comparison of Speed – Torque Characteristics

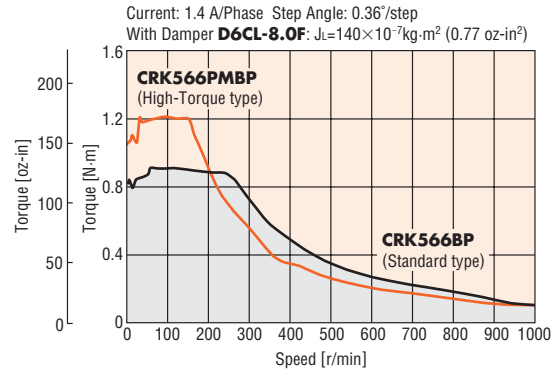

Encoder Option Available

Pulse Input Package: 500 or 1000 pulse/rev, 3 channel, TTL.
Built-In Controller Package: 500 or 1000 pulse/rev, 3 channel, Differential.

Motor rotations can be detected by taking in encoder output signals into a programmable controller (not supplied with CRK pulse input package).



Introduction	AC Input Motor & Driver
CRK566PMBP / Geared / AR	0.36° / Geared / AS
CRK566BP / Geared / RK	0.72° / Geared / UMK
CRK566AP / Geared / AR	0.9°/1.8° / Geared / ASX
CRK566PMBP / Geared / AR	0.36° / Geared / CRK
CRK566PMBP / Geared / AR	0.36° / Geared / CMK
CRK566PMBP / Geared / AR	0.9°/1.8° / Geared / RBK
CRK566PMBP / Geared / AR	1.8° / Geared / PK
CRK566PMBP / Geared / AR	0.36° / Geared / PK
CRK566PMBP / Geared / AR	0.72° / Geared / PK
CRK566PMBP / Geared / AR	0.9° / Geared / PK
CRK566PMBP / Geared / AR	Motor Only / PK / PV
CRK566PMBP / Geared / AR	1.8° / Geared / PK
CRK566PMBP / Geared / AR	Controllers / SCX10 / EMP400 / SG8030J
CRK566PMBP / Geared / AR	Accessories

● Three Control Methods

Three control methods can be selected, depending on your operation system.

◇ Pulse Input Package

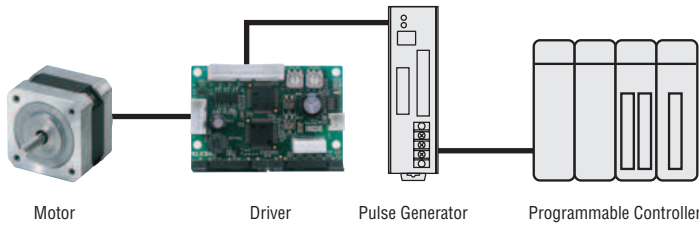

Pulse Control

The motor is controlled using a pulse generator provided by the customer. Operation data is input to the pulse generator, then selected and run from the host programmable controller.

◇ Built-In Controller Package

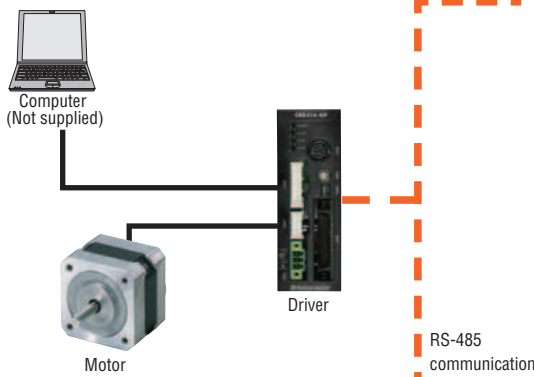

I/O Control

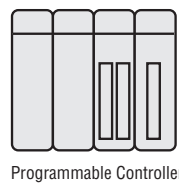

A built-in pulse generation function allows the motor to be driven via a directly connected programmable controller. Since no separate pulse generator is required, drivers of this type save space and simplify the system.

RS-485 Communication Control

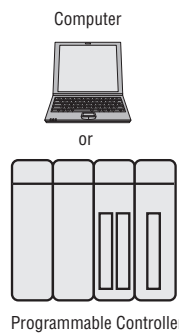

Operation data, parameter settings and operation commands can be input via RS-485 communication. A maximum of 16 drivers can be connected to one host controller.

◇ Motion Creator Software (for Built-In Controller Package)

- Easily create basic motion such as Incremental, Absolute, Linked and Continues Moves
- Use Program Editor to create complex motion profiles
- Utilize commands from built-in editor with drag and drop feature
- Easy cloning with Upload/Download functions to PC
- Use Motion Monitor to view all inputs, outputs, motor position and alarm state
- Built-in help menu

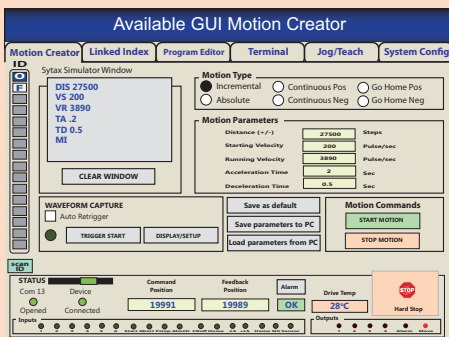

● Features of the Built-In Controller Package

The **CRK** Series with built-in controller is a compact, space saving stepping motor and driver package with a powerful, feature-rich controller built-in. The driver supports RS-485 communications with multi-drop capability for network operation and I/O control.

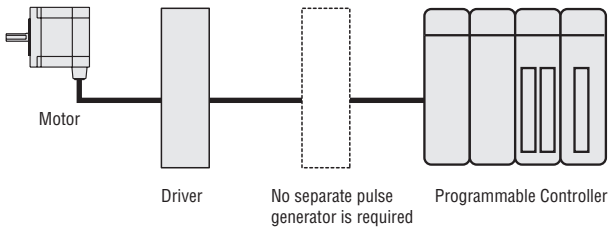

◇ Up to 64 Program Sequences

Up to 64 program sequences are available. Incremental (relative distance specification) mode and Absolute (absolute position specification) mode are available.

◇ 3 Operating Modes

- Direct command entry - from terminal, PLC or master controller
- Standalone operation - running sorted programs selected via I/O
- Variable data - any settable parameter or variable values entered changed via direct entry from a host will be used by the stored sequence.

◇ Motion Example

[Incremental Operation]

The motor's operating speed and distance of the move are set to perform according to the selected program.

● Example

Distance: 2000 steps (Incremental)
 Running Velocity: 1000 pps
 Starting Velocity: 500 pps
 Acceleration time: 0.5 sec.
 Deceleration time: 0.5 sec.

```
>DIS=2000
DIS=2000
>VR=1000
VR=1000
>VS=500
VS=500
>TA=0.5
TA=0.5
>TD=0.5
TD=0.5
>MI
>
```

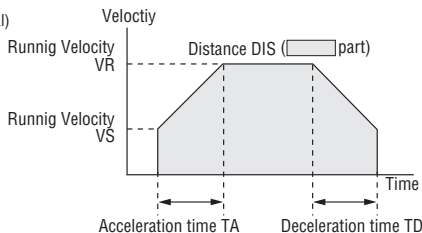

[Linked Operation]

Use up to 4 running speeds between the start and stop positions with each motion having its own distance. After "linking" the data, the different motions will be activated with a single start signal.

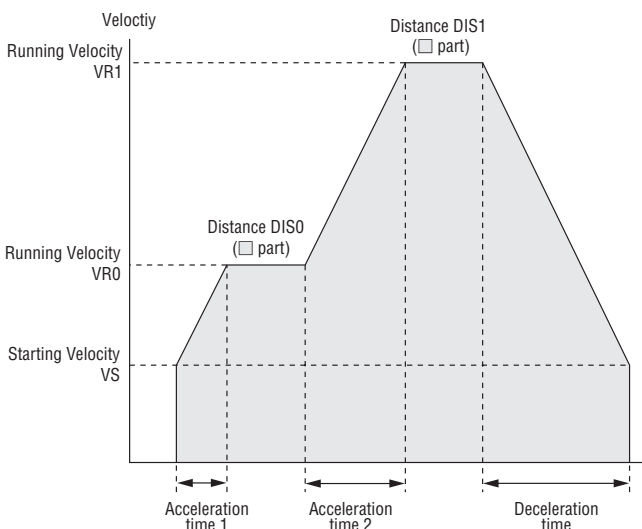

[Continuous Operation at Variable Speeds]

The motor speed can easily be changed while the motor runs continuously with a new motion command.

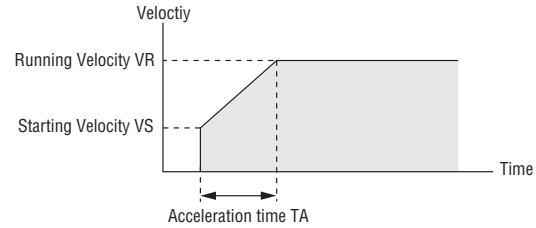

◇ Return to Home Operation

Return to Home Operation can easily be performed by a home position sensor or a sensor representing a position reference point (home) is available.

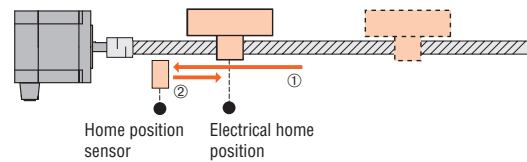

◇ PLS-OUT Output Function

● Synchronism is available

The PLS-OUT output is used to output the driver's internal oscillation pulse to a second driver allowing for the second motor to be controlled in synchronism with the first. The number of pulses to the output corresponds to the commanded travel and the pulse frequency corresponds to the operating speed.

● Used for Position Counting

By counting the output signals, the commanded position of the motor can be checked.

◇ Teaching Function

Teaching can be performed with direct commands or with the Motion Creator Software. When you move the table to the target position, it stores the achieved position as positioning data.

Introduction	DC Input Motor & Driver
AR	0.36° / Geared
AS	0.36° / Geared
RK	0.72° / Geared
UMK	0.9°/1.8°
AR	0.36° / Geared
ASX	0.36° / Geared
CRK	0.36°/0.72° / Geared
CMK	0.9°/1.8° / Geared
RBK	1.8° / Geared
PK	0.36°
PK	0.72°
PK	0.9°
PK/PV	1.8°
PK	Geared
Controllers	SCX10 / EMP400 / SG8030J
Accessories	

◇ Encoder Type Motors

Motor rotations can be detected by taking in encoder output signals into the built-in controller.

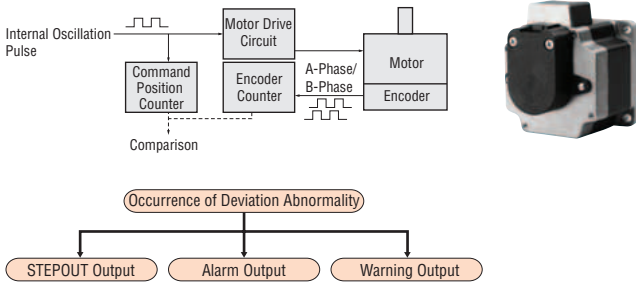

• STEPOUT Output Function

If a deviation between the driver's command position and the encoder counter value reaches the setting value (deviation abnormality), a STEPOUT signal is output. This allows for detection of positional errors caused by sudden changes in load, etc.

• Alarm Output Function*

If a deviation abnormality occurs, an overflow alarm is generated and the motor is stopped.

• Warning Output Function*

If a deviation abnormality occurs, an overflow warning is generated. The motor will continue to operate.

* Whether an alarm or warning is output when a deviation abnormality has occurred can be set with the parameters.





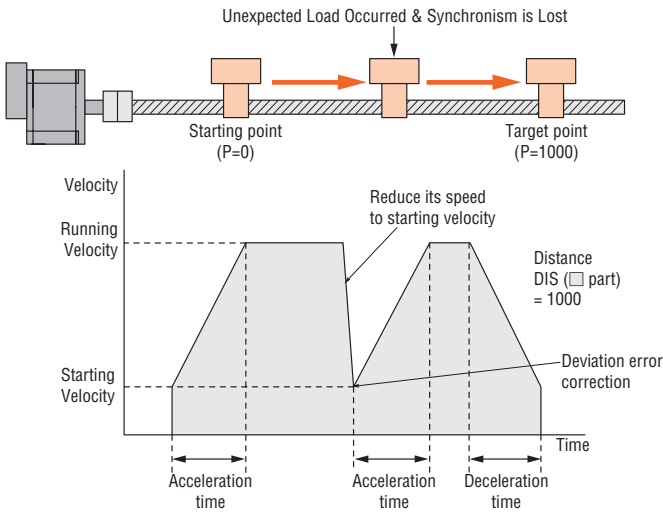

• Self Correction Function

When the Self Correcting Function is enabled and synchronism is lost, the controller makes sure that the motion profile is completed correctly. Total distance remains the same.



Lineup of Motors

Characteristics Comparison for Motors

Type	Features	Permissible Torque/ Maximum Torque [N·m (oz-in)]	Backlash [arc min]	Basic Resolution [deg/step]	Output Shaft Speed [r/min]	
Step Angle 0.36° High-Torque Type 	<ul style="list-style-type: none"> The basic step angle is 0.36°/step, which is half that of the standard type High positioning accuracy 	Maximum Holding Torque 2.3 (320)	—	0.36	4000	
Step Angle 0.72° High-Torque Type 	<ul style="list-style-type: none"> Higher torque of approximately 1.3 to 1.5 times compared with the standard type 	Maximum Holding Torque 0.42 (59)	—	0.72	4000	
Step Angle 0.72° Standard Type 	<ul style="list-style-type: none"> Basic model of CRK Series 	Maximum Holding Torque 1.66 (230)	—	0.72	4000	
Low Backlash	TH Geared Type (Parallel shaft) 	<ul style="list-style-type: none"> A wide variety of low gear ratios for high-speed operation Gear ratios: 3.6, 7.2, 10, 20, 30 	4 (35)*	60	0.024	500
	PS Geared Type (Planetary gear) 	<ul style="list-style-type: none"> High permissible/maximum torque A wide variety of gear ratios for selecting the desired step angle Centered output shaft Gear ratios: 5, 7.2, 10, 25, 36, 50 	Permissible Torque 8 (70)*	35	0.0144	600
Non-Backlash	PN Geared Type (Planetary gear) 	<ul style="list-style-type: none"> High speed (low gear ratios), high accuracy positioning High permissible/maximum torque A wide variety of gear ratios for selecting the desired step angle Centered output shaft Gear ratios: 5, 7.2, 10, 25, 36, 50 	Permissible Torque 8 (70)*	3	0.0144	600
	Harmonic Geared Type (Harmonic drive) 	<ul style="list-style-type: none"> High accuracy positioning High permissible/maximum torque High gear ratios, high resolution Centered output shaft Gear ratios: 50, 100 	Permissible Torque 8 (70)*	0	0.0072	70

* The unit of the value in the parentheses of the geared type is [lb-in].



Note

● The values shown above must be used as reference. The actual values vary depending on the motor frame size and gear ratio.

Introduction	AC Input Motor & Driver	Motor Only	Controllers
AR	0.36° / Geared	0.36°	SCX10
AS	0.72° / Geared	0.72°	EMP400
UMK	0.9°/1.8°	0.9°	SG8030J
AR	0.36° / Geared	0.36°/0.72° / Geared	Accessories
ASX	0.36° / Geared	0.9°/1.8° / Geared	
CRK	0.36°/0.72° / Geared	1.8° / Geared	
CMK	0.9°/1.8° / Geared		
RBK	1.8° / Geared		
PK	0.36°		
PK	0.72°		
PK	0.9°		
PK/PV	1.8°		
PK	Geared		

● Wide Variety

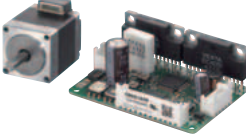
The following motor frame sizes are available, depending on whether a pulse input package or built-in controller package is used.
("□42" indicates a motor frame size of 42 mm.)

	Step Angle 0.36° High-Torque Type	Step Angle 0.72° High-Torque Type	Step Angle 0.72° Standard Type	TH Geared Type	PS Geared Type	PN Geared Type	Harmonic Geared Type
Pulse Input Packages 	□28 (□1.10) □42 (□1.65)* □60 (□2.36)*	□20 (□0.79) □28 (□1.10) □42 (□1.65)*	□42 (□1.65)* □60 (□2.36)*	□28 (□1.10) □42 (□1.65)* □60 (□2.36)*	□28 (□1.10) □42 (□1.65)* □60 (□2.36)*	□28 (□1.10) □42 (□1.65) □60 (□2.36)	□20 (□0.79) □30 (□1.18) □42 (□1.65)* □60 (□2.36)*
Built-In Controller Packages 	□28 (□1.10) □42 (□1.65)* □60 (□2.36)*	□20 (□0.79) □28 (□1.10) □42 (□1.65)*	□42 (□1.65)* □60 (□2.36)*	□28 (□1.10) □42 (□1.65)* □60 (□2.36)*	□28 (□1.10) □42 (□1.65)* □60 (□2.36)*		□20 (□0.79) □30 (□1.18) □42 (□1.65)* □60 (□2.36)*

*An encoder type is available.

System Configuration

Pulse Input Packages

An example of a system configuration with the **SG8030J** controller.

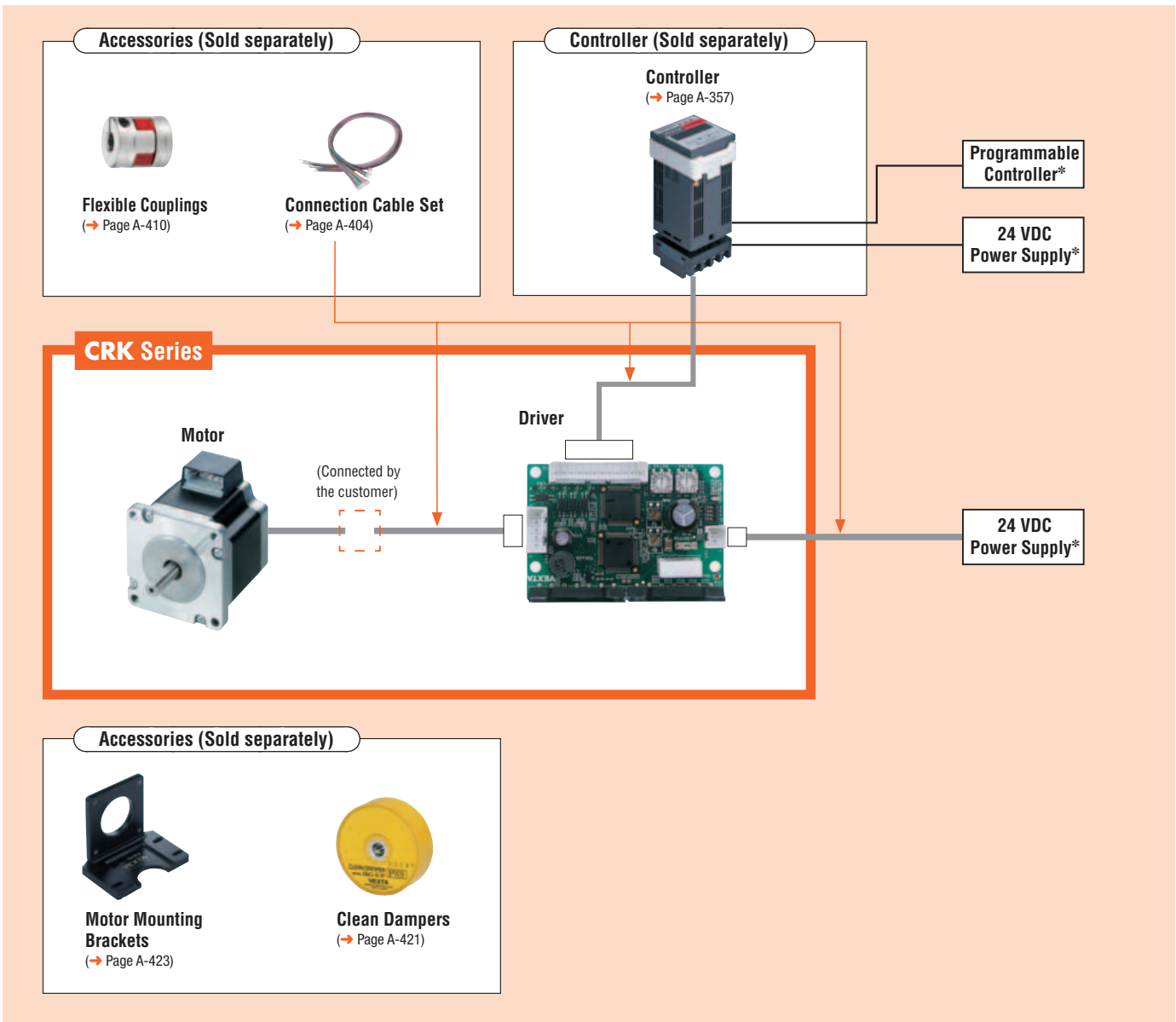

Example of System Configuration

CRK Series	Sold Separately				
	Controller	Motor Mounting Bracket	Flexible Coupling	Clean Damper	Connection Cable Set
CRK566PMBP	SG8030J-U	PAL2P-5A	MCS300808	D6CL-8.0F	LCS4SD5

● The system configuration shown above is an example. Other combinations are available.

* Not supplied

Introduction	
AC Input Motor & Driver	0.36° / Geared / AR, 0.72° / Geared / RK, 0.9° / 1.8° / UMK
DC Input Motor & Driver	0.36° / Geared / AR, 0.36° / Geared / ASX, 0.36° / Geared / CRK, 0.9° / 1.8° / Geared / CMK, 1.8° / Geared / RBK, 0.36° / PK, 0.72° / PK, 0.9° / PK, 1.8° / PK/PV, Geared / PK, Controllers / SCX10 / EMP400 / SG8030J, Accessories

System Configuration

Built-In Controller Packages

An example of a configuration when used with either I/O control or RS-485 communication.

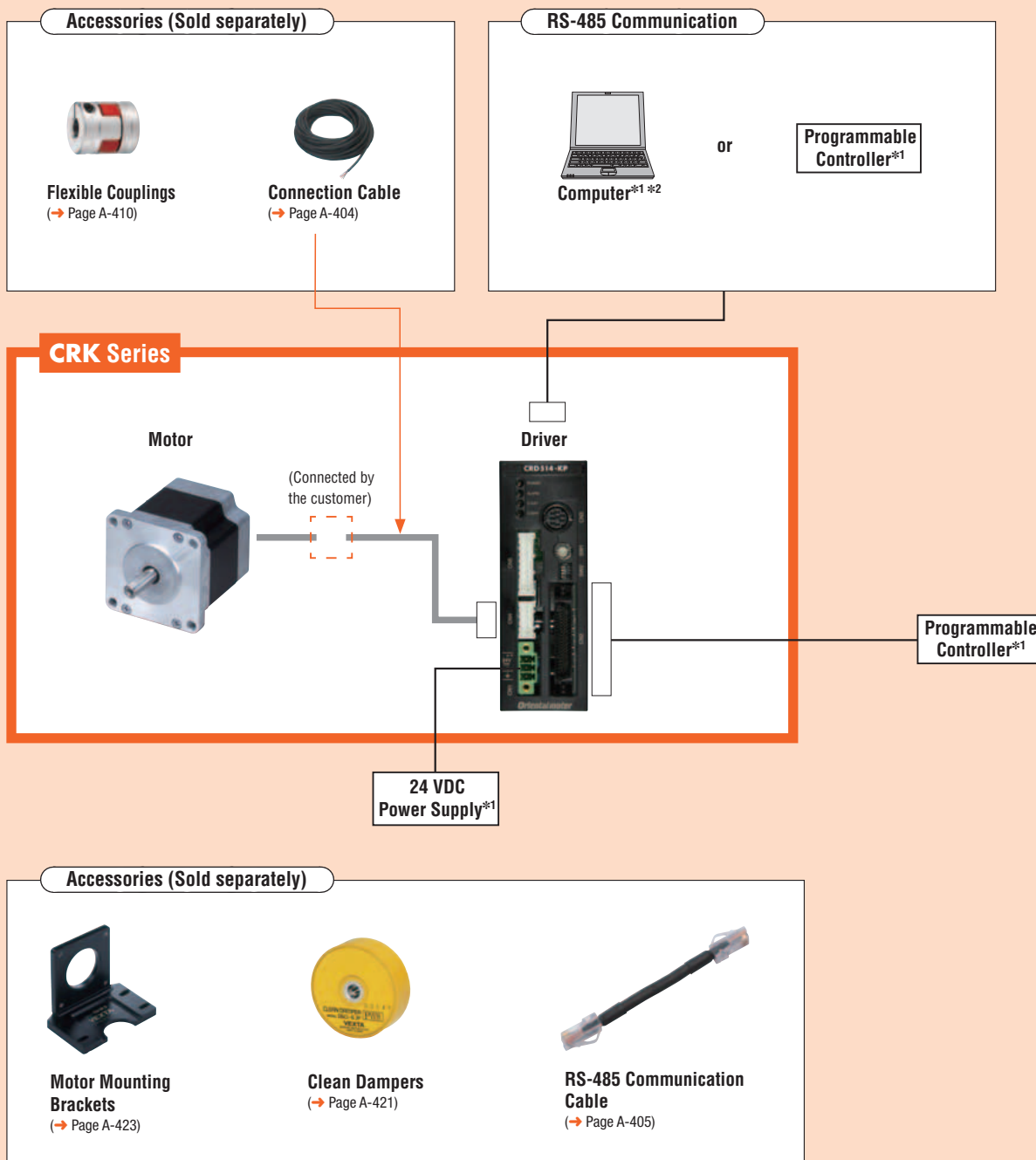

Example of System Configuration

CRK Series	Sold Separately			
	Connection Cable [5 m (16.4 ft.)]	Motor Mounting Bracket	Flexible Coupling	Clean Damper
CRK566BKP	CC05PK5	PAL2P-5A	MCS300808	D6CL-8.0F

● The system configuration shown above is an example. Other combinations are available.

*1 Not supplied

*2 Motion Creator GUI available for download. → Page A-170

Product Number Code

Pulse Input Package

◇ High-Torque Type, Standard Type

CRK 5 4 4 P M A P

① ② ③ ④ ⑤ ⑥ ⑦ ⑧

CRK 5 4 4 P M A P - R 2 8

① ② ③ ④ ⑤ ⑥ ⑦ ⑧ ⑨ ⑩ ⑪

◇ Geared Type

CRK 5 2 3 P A P - N 7.2

① ② ③ ④ ⑤ ⑥ ⑦ ⑪ ⑫

CRK 5 4 3 A P R 2 7 PS 25

① ② ③ ④ ⑥ ⑦ ⑧ ⑨ ⑩ ⑪ ⑫

Built-In Controller Package

◇ High-Torque Type, Standard Type

CRK 5 4 4 P M A K P

① ② ③ ④ ⑤ ⑥ ⑦ ⑧ ⑨

CRK 5 4 4 P M R K P

① ② ③ ④ ⑤ ⑥ ⑦ ⑧ ⑨

◇ Geared Type

CRK 5 2 3 P A K P - T 7.2

① ② ③ ④ ⑤ ⑥ ⑦ ⑧ ⑨ ⑩

CRK 5 4 3 R K P PS 25

① ② ③ ④ ⑥ ⑦ ⑧ ⑨ ⑩

①	Series	CRK: CRK Series
②	5: 5-Phase	
③	Motor Frame Size	1: 20 mm (0.79 in.) 2: 28 mm (1.10 in.) 4: 42 mm (1.65 in.) 6: 60 mm (2.36 in.)
④	Motor Case Length	
⑤	Motor Type	
⑥	Resolution	Blank: 0.72°/step (High-Torque Type, Standard Type) M: 0.36°/step (High-Torque Type)
⑦	Motor Shaft Type	A: Single Shaft B: Double Shaft
⑧	Signal I/O Mode of Driver	P: Photocoupler
⑨	Encoder Version	
⑩	Encoder Output	2: 3-Channel A, B, Index
⑪	Encoder Resolution	7: 500 P/R 8: 1000 P/R

①	Series	CRK: CRK Series
②	5: 5-Phase	
③	Motor Frame Size	1: 20 mm (0.79 in.) 2: 28 mm (1.10 in.) [30 mm (1.18 in.)] 4: 42 mm (1.65 in.) 6: 60 mm (2.36 in.)
④	Motor Case Length	
⑤	Motor Type	
⑥	Motor Shaft Type	A: Single Shaft B: Double Shaft
⑦	Signal I/O Mode of Driver	P: Photocoupler
⑧	Encoder Version	
⑨	Encoder Output	2: 3-Channel A, B, Index
⑩	Encoder Resolution	7: 500 P/R
⑪	Gearhead Type	T: TH Geared Type PS: PS Geared Type N: PN Geared Type H: Harmonic Geared Type
⑫	Gear Ratio	

①	Series	CRK: CRK Series
②	5: 5-Phase	
③	Motor Frame Size	1: 20 mm (0.79 in.) 2: 28 mm (1.10 in.) 4: 42 mm (1.65 in.) 6: 60 mm (2.36 in.)
④	Motor Case Length	
⑤	Motor Type	
⑥	Resolution	Blank: 0.72°/step (High-Torque Type, Standard Type) M: 0.36°/step (High-Torque Type)
⑦	Motor Shaft Type	A: Single Shaft B: Double Shaft R: With Encoder
⑧	Power Supply Voltage	K: 24 VDC
⑨	Driver Type	P: Built-In Controller Package

①	Series	CRK: CRK Series
②	5: 5-Phase	
③	Motor Frame Size	1: 20 mm (0.79 in.) 2: 28 mm (1.10 in.) 4: 42 mm (1.65 in.) 6: 60 mm (2.36 in.)
④	Motor Case Length	
⑤	Motor Type	
⑥	Motor Shaft Type	A: Single Shaft B: Double Shaft R: With Encoder
⑦	Power Supply Voltage	K: 24 VDC
⑧	Driver Type	P: Built-In Controller Package
⑨	Gearhead Type	T: TH Geared Type PS: PS Geared Type H: Harmonic Geared Type
⑩	Gear Ratio	

Introduction

DC Input Motor & Driver

0.36° / Geared / Geared

0.72° / Geared

0.9°/1.8°

DC Input Motor & Driver

0.36° / Geared / Geared

0.36° / Geared

0.36°/0.72° / Geared

0.9°/1.8° / Geared

1.8° / Geared

0.36°

0.72°

Motor Only

0.9°

1.8°

Geared

Controllers

SCX10 / EMP400 / SG8030J

Accessories

Product Line

● Pulse Input Package

◇ Step Angle 0.36° High-Torque Type

Model (Single shaft)	Model (Double shaft)
CRK523PMAP	CRK523PMBP
CRK524PMAP	CRK524PMBP
CRK525PMAP	CRK525PMBP
CRK544PMAP	CRK544PMBP
CRK546PMAP	CRK546PMBP
CRK564PMAP	CRK564PMBP
CRK566PMAP	CRK566PMBP
CRK569PMAP	CRK569PMBP

◇ Step Angle 0.72° High-Torque Type

Model (Single shaft)	Model (Double shaft)
CRK513PAP	CRK513PBP
CRK523PAP	CRK523PBP
CRK525PAP	CRK525PBP
CRK544PAP	CRK544PBP
CRK546PAP	CRK546PBP

◇ Step Angle 0.72° Standard Type

Model (Single shaft)	Model (Double shaft)
CRK543AP	CRK543BP
CRK544AP	CRK544BP
CRK545AP	CRK545BP
CRK564AP	CRK564BP
CRK566AP	CRK566BP
CRK569AP	CRK569BP

◇ TH Geared Type

Model (Single shaft)	Model (Double shaft)
CRK523PAP-T7.2	CRK523PBP-T7.2
CRK523PAP-T10	CRK523PBP-T10
CRK523PAP-T20	CRK523PBP-T20
CRK523PAP-T30	CRK523PBP-T30
CRK543AP-T3.6	CRK543BP-T3.6
CRK543AP-T7.2	CRK543BP-T7.2
CRK543AP-T10	CRK543BP-T10
CRK543AP-T20	CRK543BP-T20
CRK543AP-T30	CRK543BP-T30
CRK564AP-T3.6	CRK564BP-T3.6
CRK564AP-T7.2	CRK564BP-T7.2
CRK564AP-T10	CRK564BP-T10
CRK564AP-T20	CRK564BP-T20
CRK564AP-T30	CRK564BP-T30

◇ PS Geared Type

Model (Single shaft)	Model (Double shaft)
CRK523PAP-PS5	CRK523PBP-PS5
CRK523PAP-PS7	CRK523PBP-PS7
CRK523PAP-PS10	CRK523PBP-PS10
CRK545AP-PS5	CRK545BP-PS5
CRK545AP-PS7	CRK545BP-PS7
CRK545AP-PS10	CRK545BP-PS10
CRK543AP-PS25	CRK543BP-PS25
CRK543AP-PS36	CRK543BP-PS36
CRK543AP-PS50	CRK543BP-PS50
CRK566AP-PS5	CRK566BP-PS5
CRK566AP-PS7	CRK566BP-PS7
CRK566AP-PS10	CRK566BP-PS10
CRK564AP-PS25	CRK564BP-PS25
CRK564AP-PS36	CRK564BP-PS36
CRK564AP-PS50	CRK564BP-PS50

◇ Step Angle 0.36° High-Torque Type with Encoders

Model
CRK544PMAP-R28
CRK546PMAP-R28
CRK564PMAP-R28
CRK566PMAP-R28
CRK569PMAP-R28

◇ Step Angle 0.72° High-Torque Type with Encoders

Model
CRK544PAP-R27
CRK546PAP-R27

◇ Step Angle 0.72° Standard Type with Encoders

Model
CRK543AP-R27
CRK544AP-R27
CRK545AP-R27
CRK564AP-R27
CRK566AP-R27
CRK569AP-R27

◇ TH Geared Type with Encoders

Model
CRK543APR27T3.6
CRK543APR27T7.2
CRK543APR27T10
CRK543APR27T20
CRK543APR27T30
CRK564APR27T3.6
CRK564APR27T7.2
CRK564APR27T10
CRK564APR27T20
CRK564APR27T30

◇ PS Geared Type with Encoders

Model
CRK545APR27PS5
CRK545APR27PS7
CRK545APR27PS10
CRK543APR27PS25
CRK543APR27PS36
CRK543APR27PS50
CRK566APR27PS5
CRK566APR27PS7
CRK566APR27PS10
CRK564APR27PS25
CRK564APR27PS36
CRK564APR27PS50

◇ PN Geared Type

Model (Single shaft)	Model (Double shaft)
CRK523PAP-N5	CRK523PBP-N5
CRK523PAP-N7.2	CRK523PBP-N7.2
CRK523PAP-N10	CRK523PBP-N10
CRK544AP-N5	CRK544BP-N5
CRK544AP-N7.2	CRK544BP-N7.2
CRK544AP-N10	CRK544BP-N10
CRK566AP-N5	CRK566BP-N5
CRK566AP-N7.2	CRK566BP-N7.2
CRK566AP-N10	CRK566BP-N10
CRK564AP-N25	CRK564BP-N25
CRK564AP-N36	CRK564BP-N36
CRK564AP-N50	CRK564BP-N50

◇ Harmonic Geared Type

Model (Single shaft)	Model (Double shaft)
CRK513PAP-H50	CRK513PBP-H50
CRK513PAP-H100	CRK513PBP-H100
CRK523PAP-H50	CRK523PBP-H50
CRK523PAP-H100	CRK523PBP-H100
CRK543AP-H50	CRK543BP-H50
CRK543AP-H100	CRK543BP-H100
CRK564AP-H50	CRK564BP-H50
CRK564AP-H100	CRK564BP-H100

The following items are included in each product.

Motor, Parallel Key*1, Driver, Driver Connector, Connection Cable*2, Encoder Connection Cable*3, Operating Manual

*1 Only for the products with a key slot on the output shaft

*2 Only for connector-coupled motor

*3 Only for the products with an encoder

● Built-In Controller Package

◇ Step Angle 0.36°

High-Torque Type

Model (Single shaft)	Model (Double shaft)
CRK523PMAKP	CRK523PMBKP
CRK524PMAKP	CRK524PMBKP
CRK525PMAKP	CRK525PMBKP
CRK544PMAKP	CRK544PMBKP
CRK546PMAKP	CRK546PMBKP
CRK564PMAKP	CRK564PMBKP
CRK566PMAKP	CRK566PMBKP
CRK569PMAKP	CRK569PMBKP

◇ Step Angle 0.72°

High-Torque Type

Model (Single shaft)	Model (Double shaft)
CRK513PAKP	CRK513PBKP
CRK523PAKP	CRK523PBKP
CRK525PAKP	CRK525PBKP
CRK544PAKP	CRK544PBKP
CRK546PAKP	CRK546PBKP

◇ Step Angle 0.72°

Standard Type

Model (Single shaft)	Model (Double shaft)
CRK543AKP	CRK543BKP
CRK544AKP	CRK544BKP
CRK545AKP	CRK545BKP
CRK564AKP	CRK564BKP
CRK566AKP	CRK566BKP
CRK569AKP	CRK569BKP

The following items are included in each product.

Motor, Parallel Key*1, Driver, Power Supply Connector, Connection Cable*2, Encoder Connection Cable*3, CN2 Connection Cable, CN4 Connection Cable, CN5 Connection Cable*3, Operating Manual

*1 Only for the products with a key slot on the output shaft

*2 Only for connector-coupled motor

*3 Only for the products with an encoder

◇ Harmonic Geared Type with Encoders

Model
CRK543APR27H50
CRK543APR27H100
CRK564APR27H50
CRK564APR27H100

◇ Step Angle 0.36°

High-Torque Type with Encoders

Model
CRK544PMRKP
CRK546PMRKP
CRK564PMRKP
CRK566PMRKP
CRK569PMRKP

◇ Step Angle 0.72°

High-Torque Type with Encoders

Model
CRK544PRKP
CRK546PRKP

◇ Step Angle 0.72°

Standard Type with Encoders

Model
CRK543RKP
CRK544RKP
CRK545RKP
CRK564RKP
CRK566RKP
CRK569RKP

◇ TH Geared Type

Model (Single shaft)	Model (Double shaft)
CRK523PAKP-T7.2	CRK523PBKP-T7.2
CRK523PAKP-T10	CRK523PBKP-T10
CRK523PAKP-T20	CRK523PBKP-T20
CRK523PAKP-T30	CRK523PBKP-T30
CRK543AKP-T3.6	CRK543BKP-T3.6
CRK543AKP-T7.2	CRK543BKP-T7.2
CRK543AKP-T10	CRK543BKP-T10
CRK543AKP-T20	CRK543BKP-T20
CRK543AKP-T30	CRK543BKP-T30
CRK564AKP-T3.6	CRK564BKP-T3.6
CRK564AKP-T7.2	CRK564BKP-T7.2
CRK564AKP-T10	CRK564BKP-T10
CRK564AKP-T20	CRK564BKP-T20
CRK564AKP-T30	CRK564BKP-T30

◇ PS Geared Type

Model (Single shaft)	Model (Double shaft)
CRK523PAKP-PS5	CRK523PBKP-PS5
CRK523PAKP-PS7	CRK523PBKP-PS7
CRK523PAKP-PS10	CRK523PBKP-PS10
CRK545AKP-PS5	CRK545BKP-PS5
CRK545AKP-PS7	CRK545BKP-PS7
CRK545AKP-PS10	CRK545BKP-PS10
CRK543AKP-PS25	CRK543BKP-PS25
CRK543AKP-PS36	CRK543BKP-PS36
CRK543AKP-PS50	CRK543BKP-PS50
CRK566AKP-PS5	CRK566BKP-PS5
CRK566AKP-PS7	CRK566BKP-PS7
CRK566AKP-PS10	CRK566BKP-PS10
CRK564AKP-PS25	CRK564BKP-PS25
CRK564AKP-PS36	CRK564BKP-PS36
CRK564AKP-PS50	CRK564BKP-PS50

◇ Harmonic Geared Type

Model (Single shaft)	Model (Double shaft)
CRK513PAKP-H50	CRK513PBKP-H50
CRK513PAKP-H100	CRK513PBKP-H100
CRK523PAKP-H50	CRK523PBKP-H50
CRK523PAKP-H100	CRK523PBKP-H100
CRK543AKP-H50	CRK543BKP-H50
CRK543AKP-H100	CRK543BKP-H100
CRK564AKP-H50	CRK564BKP-H50
CRK564AKP-H100	CRK564BKP-H100

◇ TH Geared Type with Encoders

Model
CRK543RKPT3.6
CRK543RKPT7.2
CRK543RKPT10
CRK543RKPT20
CRK543RKPT30
CRK564RKPT3.6
CRK564RKPT7.2
CRK564RKPT10
CRK564RKPT20
CRK564RKPT30

◇ PS Geared Type with Encoders

Model
CRK545RKPPS5
CRK545RKPPS7
CRK545RKPPS10
CRK543RKPPS25
CRK543RKPPS36
CRK543RKPPS50
CRK566RKPPS5
CRK566RKPPS7
CRK566RKPPS10
CRK564RKPPS25
CRK564RKPPS36
CRK564RKPPS50

◇ Harmonic Geared Type with Encoders

Model
CRK543RKPH50
CRK543RKPH100
CRK564RKPH50
CRK564RKPH100

The following items are included in each product.

Motor, Parallel Key*1, Driver, Power Supply Connector, Connection Cable*2, Encoder Connection Cable*3, CN2 Connection Cable, CN4 Connection Cable, CN5 Connection Cable*3, Operating Manual

*1 Only for the products with a key slot on the output shaft

*2 Only for connector-coupled motor

*3 Only for the products with an encoder

Step Angle 0.36° Motor Frame Size 28 mm (1.10 in.), 42 mm (1.65 in.)

High-Torque Type

Specifications (RoHS)



Model	Pulse Input Package		CRK523PMAP	CRK524PMAP	CRK525PMAP	CRK544PMAP	CRK546PMAP
	Double Shaft		CRK523PMBP	CRK524PMBP	CRK525PMBP	CRK544PMBP	CRK546PMBP
Model	Built-In Controller Package		CRK523PMAKP	CRK524PMAKP	CRK525PMAKP	CRK544PMAKP	CRK546PMAKP
	Double Shaft		CRK523PMBKP	CRK524PMBKP	CRK525PMBKP	CRK544PMBKP	CRK546PMBKP
Maximum Holding Torque	N-m (oz-in)		0.042 (5.9)	0.061 (8.6)	0.09 (12.7)	0.24 (34)	0.42 (59)
Holding Torque at Motor Standstill	Power ON	N-m (oz-in)	0.019 (2.6)	0.028 (3.9)	0.041 (5.8)	0.11 (15.6)	0.19 (26)
Rotor Inertia	J: kg·m ² (oz-in ²)		9×10 ⁻⁷ (0.049)	13×10 ⁻⁷ (0.071)	19×10 ⁻⁷ (0.104)	60×10 ⁻⁷ (0.33)	121×10 ⁻⁷ (0.66)
Rated Current	A/Phase		0.35			0.75	
Basic Step Angle			0.36°				
Power Source			24 VDC±10% 0.7 A			24 VDC±10% 1.4 A	
Excitation Mode			Microstep				

*1 Certification for UL standards is only acquired on pulse input package.

*2 Encoder connection cable [0.6 m (2 ft.)] is included with the motor with encoder and driver package.

● Connection Cable [0.6 m (2 ft.)] is included with the connector-coupled motor and driver package.

Speed – Torque Characteristics

CRK523PM

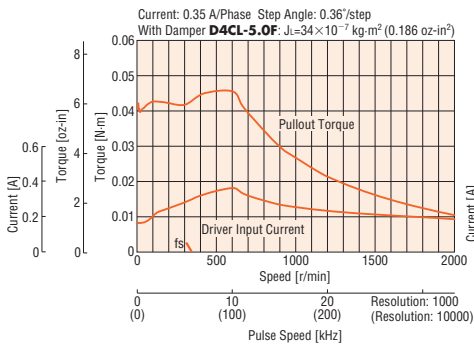

CRK524PM

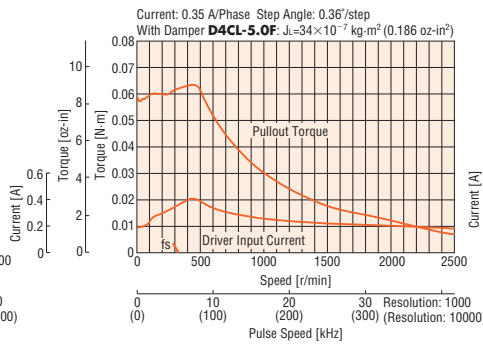

CRK525PM

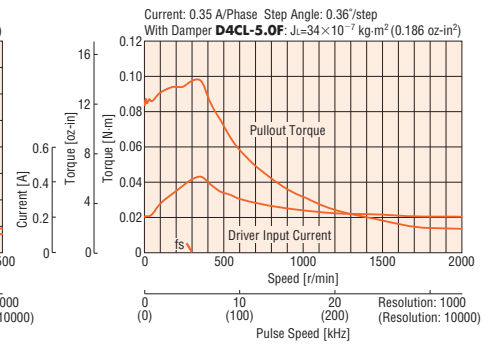

CRK544PM

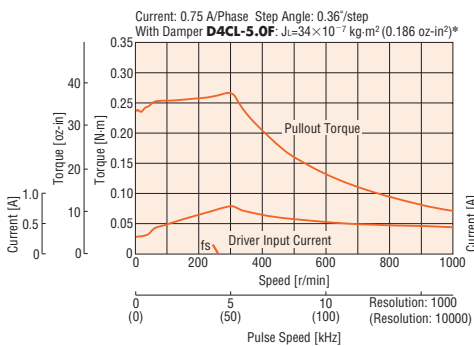

CRK546PM

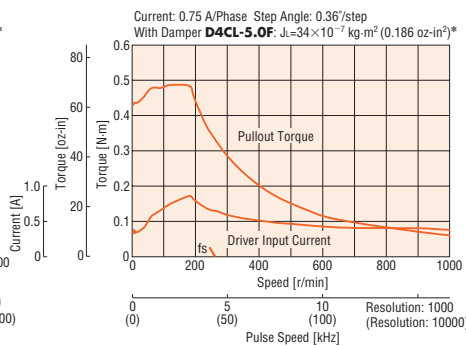

* For motors with an encoder, a load with a similar inertia should be attached.

● The pulse input circuit responds to approximately 500 kHz with a pulse duty of 50%.

Note

● Pay attention to heat dissipation from motor as there will be a considerable amount of heat under certain conditions. Be sure to keep the temperature of the motor case under 100°C (212°F). [Under 75°C (167°F) is required to comply with UL or CSA Standards as the motor is recognized as Thermal Class 105 (A).]

Introduction
AC Input Motor & Driver
Geared / 0.36° / 0.72° / 0.9° / 1.8°
AR / AS / ASX / CRK / CMK / RBK / PK / PV / Geared / Controllers / SCX10 / EMP400 / SG8030J / Accessories

Step Angle 0.36° Motor Frame Size 60 mm (2.36 in.)

High-Torque Type

Specifications RoHS



Model	Pulse Input Package	Single Shaft	CRK564PMAP	CRK566PMAP	CRK569PMAP
		Double Shaft	CRK564PMBP	CRK566PMBP	CRK569PMBP
		With Encoder*2	CRK564PMAP-R28	CRK566PMAP-R28	CRK569PMAP-R28
	Built-In Controller Package	Single Shaft	CRK564PMAKP	CRK566PMAKP	CRK569PMAKP
		Double Shaft	CRK564PMBKP	CRK566PMBKP	CRK569PMBKP
		With Encoder*2	CRK564PMRKP	CRK566PMRKP	CRK569PMRKP
Maximum Holding Torque		N-m (oz-in)	0.78 (110)	1.3 (184)	2.3 (320)
Holding Torque at Motor Standstill	Power ON	N-m (oz-in)	0.35 (49)	0.58 (82)	1 (142)
Rotor Inertia		J: kg-m ² (oz-in ²)	310×10 ⁻⁷ (1.7)	490×10 ⁻⁷ (2.7)	970×10 ⁻⁷ (5.3)
Rated Current		A/Phase	1.4		
Basic Step Angle			0.36°		
Power Source			24 VDC±10% 2.5 A		
Excitation Mode			Microstep		

*1 Certification for UL standards is only acquired on pulse input package.

*2 Encoder connection cable [0.6 m (2 ft.)] is included with the motor with encoder and driver package.

● Connection Cable [0.6 m (2 ft.)] is included with the connector-coupled motor and driver package.

Speed – Torque Characteristics

CRK564PM

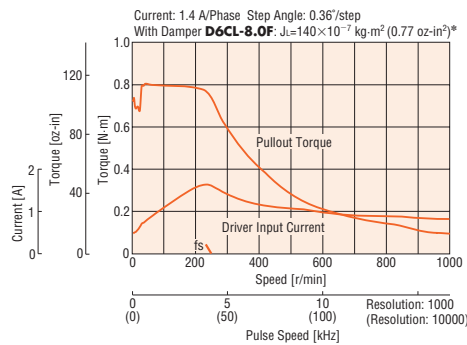

CRK566PM

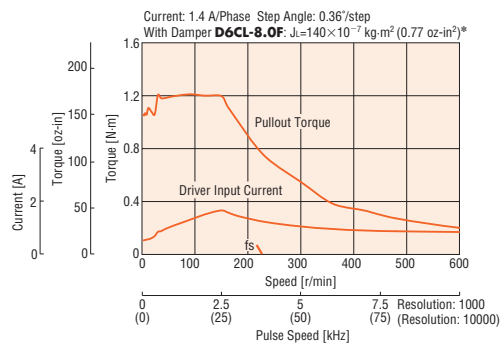

CRK569PM

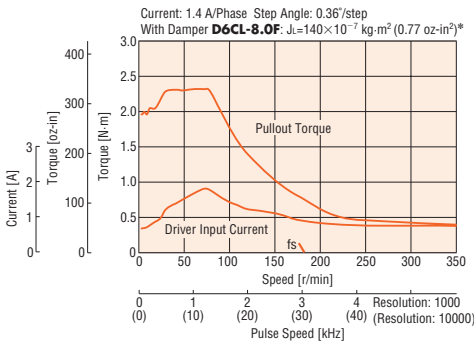

* For motors with an encoder, a load with a similar inertia should be attached.

● The pulse input circuit responds to approximately 500 kHz with a pulse duty of 50%.

Note

● Pay attention to heat dissipation from motor as there will be a considerable amount of heat under certain conditions. Be sure to keep the temperature of the motor case under 100°C (212°F). [Under 75°C (167°F) is required to comply with UL or CSA Standards as the motor is recognized as Thermal Class 105 (A).]

Step Angle 0.72° Motor Frame Size 20 mm (0.79 in.), 28 mm (1.10 in.)

High-Torque Type

Specifications RoHS



Model	Pulse Input Package	Single Shaft	CRK513PAP	CRK523PAP	CRK525PAP
	Built-In Controller Package	Double Shaft	CRK513PBP	CRK523PBP	CRK525PBP
		Single Shaft	CRK513PAKP	CRK523PAKP	CRK525PAKP
		Double Shaft	CRK513PBKP	CRK523PBKP	CRK525PBKP
Maximum Holding Torque	N-m (oz-in)		0.0231 (3.2)	0.048 (8.8)	0.078 (11)
Holding Torque at Motor Standstill	Power ON	N-m (oz-in)	0.011 (1.56)	0.023 (3.2)	0.037 (5.2)
Rotor Inertia	J: kg·m ² (oz-in ²)		1.6 × 10 ⁻⁷ (0.0088)	9 × 10 ⁻⁷ (0.049)	18 × 10 ⁻⁷ (0.098)
Rated Current	A/Phase		0.35		
Basic Step Angle			0.72°		
Power Source			24 VDC ± 10% 0.7 A		
Excitation Mode			Microstep		

* Certification for UL standards is only acquired on pulse input package.

● Connection Cable [0.6 m (2 ft.)] is included with the connector-coupled motor and driver package.

Speed – Torque Characteristics

CRK513P

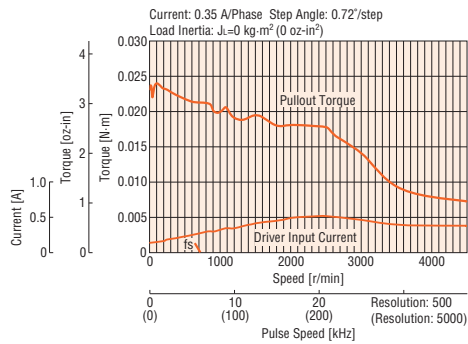

CRK523P

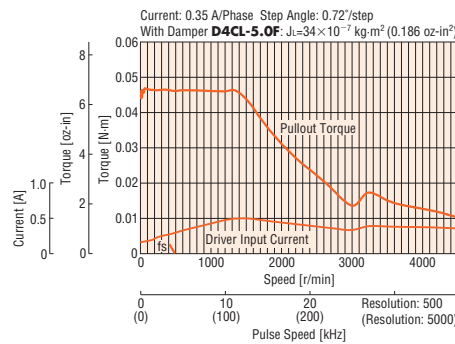

CRK525P

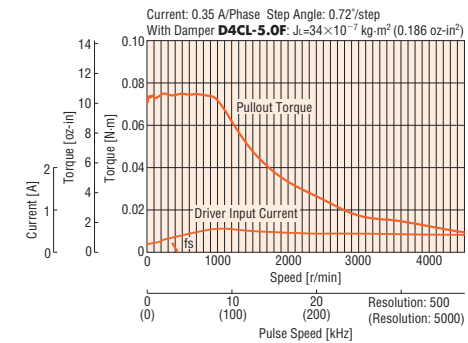

● The pulse input circuit responds to approximately 500 kHz with a pulse duty of 50%.

Note

● Pay attention to heat dissipation from motor as there will be a considerable amount of heat under certain conditions. Be sure to keep the temperature of the motor case under 100°C (212°F). [Under 75°C (167°F) is required to comply with UL or CSA Standards as the motor is recognized as Thermal Class 105 (A).]

Introduction	AC Input Motor & Driver
AR	0.36° / Geared
AS	0.72° / Geared
RK	0.9°/1.8°
UMK	0.9°/1.8°
ASX	0.36° / Geared
CRK	0.36° / Geared
CMK	0.36° / Geared
RBK	1.8° / Geared
PK	0.36°
PK	0.72°
PK	0.9°
PK/PV	1.8°
PK	Geared
SCX10 / EMP400 / SG8030J	Controllers
	Accessories

Step Angle 0.72° Motor Frame Size 42 mm (1.65 in.)

Standard/High-Torque Type

Specifications RoHS



Model	Pulse Input Package	Single Shaft	CRK543AP	CRK544AP	CRK545AP	CRK544PAP ^{*2}	CRK546PAP ^{*2}
		Double Shaft	CRK543BP	CRK544BP	CRK545BP	CRK544PBP ^{*2}	CRK546PBP ^{*2}
	With Encoder ^{*3}	CRK543AP-R27	CRK544AP-R27	CRK545AP-R27	CRK544PAP-R27 ^{*2}	CRK546PAP-R27 ^{*2}	
Built-In Controller Package	Single Shaft	CRK543AKP	CRK544AKP	CRK545AKP	CRK544PAKP ^{*2}	CRK546PAKP ^{*2}	
	Double Shaft	CRK543BKP	CRK544BKP	CRK545BKP	CRK544PBKP ^{*2}	CRK546PBKP ^{*2}	
	With Encoder ^{*3}	CRK543RKP	CRK544RKP	CRK545RKP	CRK544PRKP ^{*2}	CRK546PRKP ^{*2}	
Maximum Holding Torque		N-m (oz-in)	0.13 (18.4)	0.18 (25)	0.24 (34)	0.24 (34)	0.42 (59)
Holding Torque at Motor Standstill	Power ON	N-m (oz-in)	0.061 (8.6)	0.085 (12.0)	0.114 (16.1)		0.2 (28)
Rotor Inertia		J: kg-m ² (oz-in ²)	35×10 ⁻⁷ (0.191)	54×10 ⁻⁷ (0.3)	68×10 ⁻⁷ (0.37)	57×10 ⁻⁷ (0.31)	114×10 ⁻⁷ (0.62)
Rated Current		A/Phase	0.75				
Basic Step Angle			0.72°				
Power Source			24 VDC±10% 1.4 A				
Excitation Mode			Microstep				

*1 Certification for UL standards is only acquired on pulse input package.

*2 Connection Cable [0.6 m (2 ft.)] is included with the connector-coupled motor and driver package.

*3 Encoder connection cable [0.6 m (2 ft.)] is included with the motor with encoder and driver package.

Speed – Torque Characteristics

CRK543

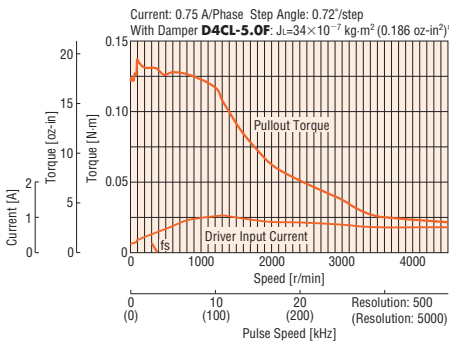

CRK544

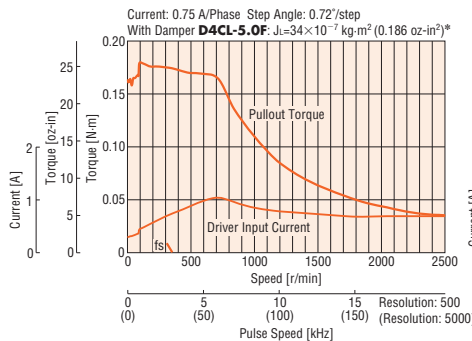

CRK545

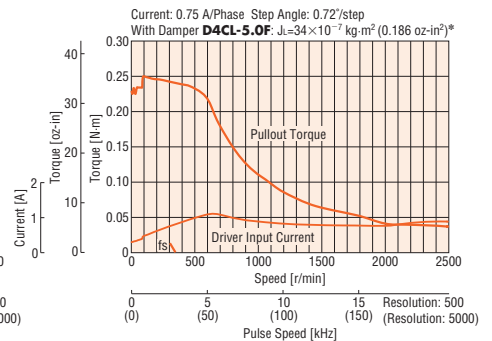

CRK544P

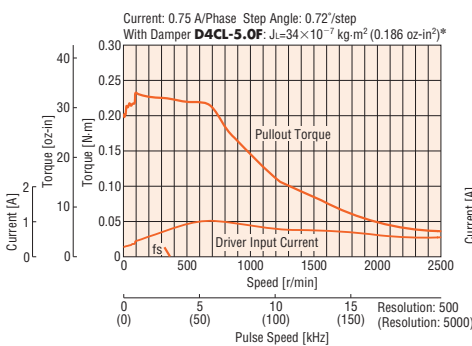

CRK546P

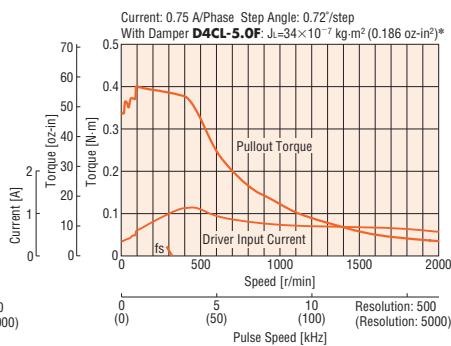

*For motors with an encoder, a load with a similar inertia should be attached.

● The pulse input circuit responds to approximately 500 kHz with a pulse duty of 50%.

Note

● Pay attention to heat dissipation from motor as there will be a considerable amount of heat under certain conditions. Be sure to keep the temperature of the motor case under 100°C (212°F). [Under 75°C (167°F) is required to comply with UL or CSA Standards as the motor is recognized as Thermal Class 105 (A).]

Step Angle 0.72° Motor Frame Size 60 mm (2.36 in.)

Standard Type

Specifications RoHS



Model	Pulse Input Package	Single Shaft		CRK564AP		CRK566AP		CRK569AP	
		Double Shaft		CRK564BP		CRK566BP		CRK569BP	
		With Encoder*2		CRK564AP-R27		CRK566AP-R27		CRK569AP-R27	
		Single Shaft		CRK564AKP		CRK566AKP		CRK569AKP	
		Double Shaft		CRK564BKP		CRK566BKP		CRK569BKP	
		With Encoder*2		CRK564RKP		CRK566RKP		CRK569RKP	
Maximum Holding Torque		N-m (oz-in)		0.42 (59)		0.83 (117)		1.66 (230)	
Holding Torque at Motor Standstill Power ON		N-m (oz-in)		0.2 (28)		0.38 (53)		0.79 (112)	
Rotor Inertia		J: kg·m ² (oz-in ²)		175×10 ⁻⁷ (0.96)		280×10 ⁻⁷ (1.53)		560×10 ⁻⁷ (3.1)	
Rated Current		A/Phase		1.4		1.4		1.4	
Basic Step Angle				0.72°		0.72°		0.72°	
Power Source				24 VDC ±10%		2.5 A		2.5 A	
Excitation Mode				Microstep		Microstep		Microstep	

*1 Certification for UL standards is only acquired on pulse input package.

*2 Encoder connection cable [0.6 m (2 ft.)] is included with the motor with encoder and driver package.

Speed – Torque Characteristics

CRK564

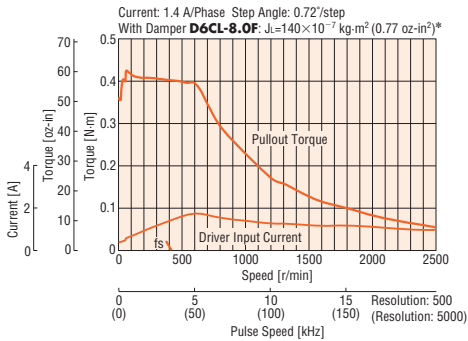

CRK566

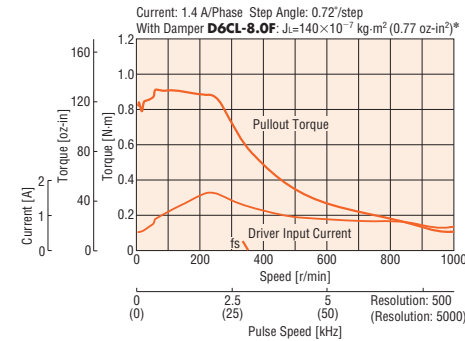

CRK569

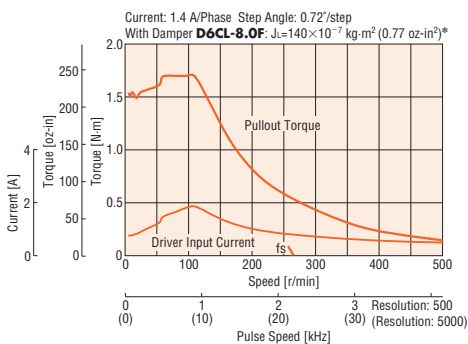

* For motors with an encoder, a load with a similar inertia should be attached.

● The pulse input circuit responds to approximately 500 kHz with a pulse duty of 50%.

Note

● Pay attention to heat dissipation from motor as there will be a considerable amount of heat under certain conditions. Be sure to keep the temperature of the motor case under 100°C (212°F). [Under 75°C (167°F) is required to comply with UL or CSA Standards as the motor is recognized as Thermal Class 105 (A).]

Introduction
 AC Input Motor & Driver
 0.36° / Geared / CRK564AP, CRK566AP, CRK569AP
 0.72° / Geared / CRK564BP, CRK566BP, CRK569BP
 0.9° / 1.8° / Geared / CRK564AKP, CRK566AKP, CRK569AKP
 0.9° / 1.8° / Geared / CRK564BKP, CRK566BKP, CRK569BKP
 1.8° / Geared / CRK564RKP, CRK566RKP, CRK569RKP
 Motor Only
 0.36° / PK
 0.72° / PK
 0.9° / PK
 1.8° / PK/PV
 Geared / PK
 Controllers / SCX10, EMP400, /SG8030J
 Accessories

TH Geared Type Motor Frame Size 28 mm (1.10 in.)

Specifications RoHS



Model	Pulse Input Package	Single Shaft	CRK523PAP-T7.2	CRK523PAP-T10	CRK523PAP-T20	CRK523PAP-T30
	Built-In Controller Package	Double Shaft	CRK523PBP-T7.2	CRK523PBP-T10	CRK523PBP-T20	CRK523PBP-T30
		Single Shaft	CRK523PAKP-T7.2	CRK523PAKP-T10	CRK523PAKP-T20	CRK523PAKP-T30
		Double Shaft	CRK523PBKP-T7.2	CRK523PBKP-T10	CRK523PBKP-T20	CRK523PBKP-T30
Maximum Holding Torque		N·m (oz·in)	0.2 (28)	0.3 (42)	0.4 (56)	0.5 (71)
Rotor Inertia		J: kg·m ² (oz·in ²)	9 × 10 ⁻⁷ (0.049)			
Rated Current		A/Phase	0.35			
Basic Step Angle			0.1°	0.072°	0.036°	0.024°
Gear Ratio			7.2	10	20	30
Permissible Torque		N·m (oz·in)	0.2 (28)	0.3 (42)	0.4 (56)	0.5 (71)
Holding Torque at Motor Standstill	Power ON	N·m (oz·in)	0.17 (24)	0.24 (34)	0.4 (56)	0.5 (71)
Backlash		arc minute (degrees)	60 (1°)			
Permissible Speed Range		r/min	0~416	0~300	0~150	0~100
Power Source			24 VDC ± 10% 0.7 A			
Excitation Mode			Microstep			

* Certification for UL standards is only acquired on pulse input package.

● Connection Cable [0.6 m (2 ft.)] is included with the connector-coupled motor and driver package.

Note

● Direction of rotation of the motor and that of the gear output shaft are the opposite for the gear ratios 7.2 and 10. It is the same for 20 and 30 gear ratios.

Speed – Torque Characteristics

CRK523 Gear Ratio 7.2

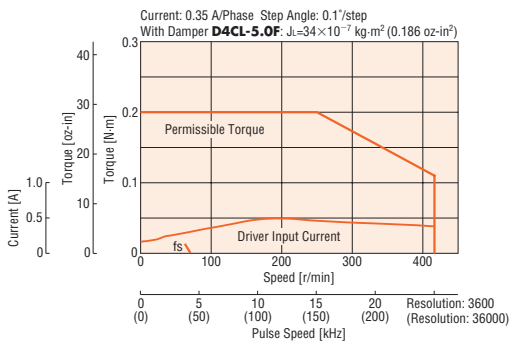

CRK523 Gear Ratio 10

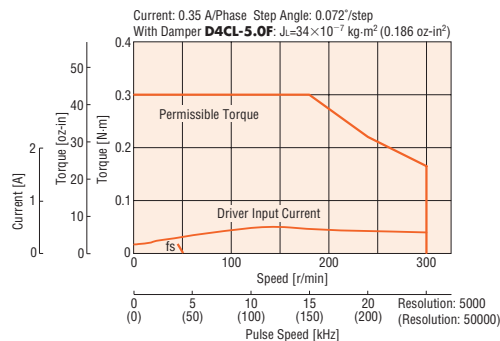

CRK523 Gear Ratio 20

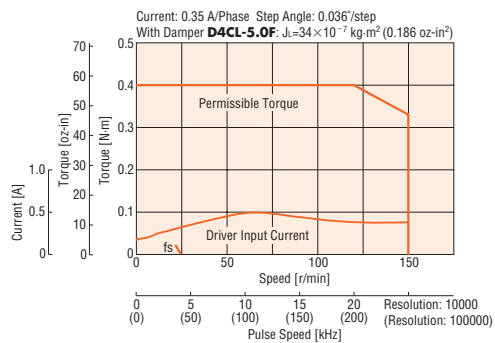

CRK523 Gear Ratio 30

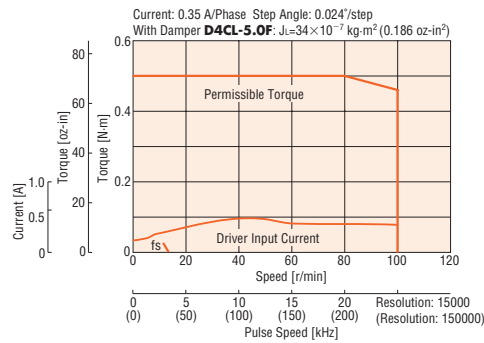

● The pulse input circuit responds to approximately 500 kHz with a pulse duty of 50%.

Note

● Pay attention to heat dissipation from motor as there will be a considerable amount of heat under certain conditions. Be sure to keep the temperature of the motor case under 100°C (212°F). [Under 75°C (167°F) is required to comply with UL or CSA Standards as the motor is recognized as Thermal Class 105 (A).]

TH Geared Type Motor Frame Size 42 mm (1.65 in.)

Specifications RoHS



Model	Pulse Input Package		CRK543AP-T3.6	CRK543AP-T7.2	CRK543AP-T10	CRK543AP-T20	CRK543AP-T30	
	Single Shaft	Double Shaft	CRK543BP-T3.6	CRK543BP-T7.2	CRK543BP-T10	CRK543BP-T20	CRK543BP-T30	
Built-In Controller Package	With Encoder*2		CRK543APR27T3.6	CRK543APR27T7.2	CRK543APR27T10	CRK543APR27T20	CRK543APR27T30	
	Single Shaft	Double Shaft	CRK543AKP-T3.6	CRK543AKP-T7.2	CRK543AKP-T10	CRK543AKP-T20	CRK543AKP-T30	
		With Encoder*2	CRK543BKP-T3.6	CRK543BKP-T7.2	CRK543BKP-T10	CRK543BKP-T20	CRK543BKP-T30	
Maximum Holding Torque		N·m (lb·in)	0.35 (3)	0.7 (6.1)	1 (8.8)	1.5 (13.2)		
Rotor Inertia		J: kg·m ² (oz·in ²)	35×10 ⁻⁷ (0.191)					
Rated Current		A/Phase	0.75					
Basic Step Angle			0.2°	0.1°	0.072°	0.036°	0.024°	
Gear Ratio			3.6	7.2	10	20	30	
Permissible Torque		N·m (lb·in)	0.35 (3)	0.7 (6.1)	1 (8.8)	1.5 (13.2)		
Holding Torque at Motor Standstill Power ON		N·m (lb·in)	0.23 (2.0)	0.46 (4.0)	0.65 (5.7)	1.3 (11.5)	1.5 (13.2)	
Backlash		arc minute (degrees)	45 (0.75°)		25 (0.42°)	15 (0.25°)		
Permissible Speed Range		r/min	0~500	0~250	0~180	0~90	0~60	
Power Source			24 VDC ±10% 1.4 A					
Excitation Mode			Microstep					

*1 Certification for UL standards is only acquired on pulse input package.

*2 Encoder connection cable [0.6 m (2 ft.)] is included with the motor with encoder and driver package.

Note

● Direction of rotation of the motor and that of the gear output shaft are the same for the gear ratios 3.6, 7.2 and 10. It is the opposite for 20 and 30 gear ratios.

Speed – Torque Characteristics

CRK543 Gear Ratio 3.6

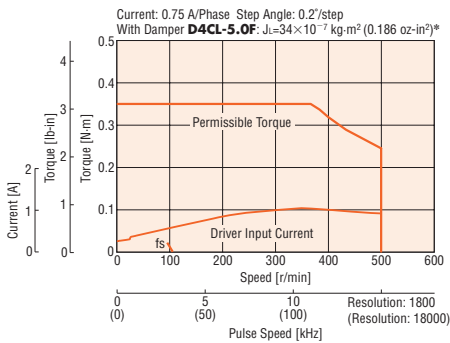

CRK543 Gear Ratio 7.2

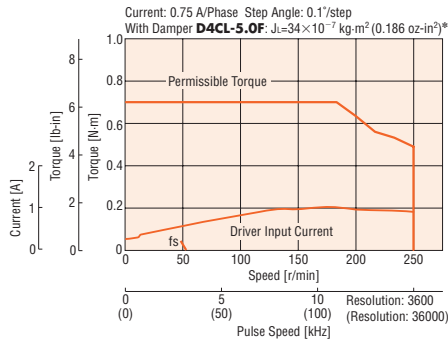

CRK543 Gear Ratio 10

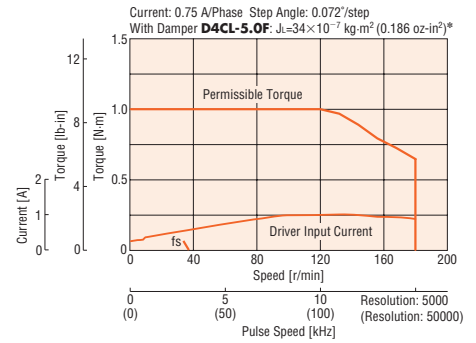

CRK543 Gear Ratio 20

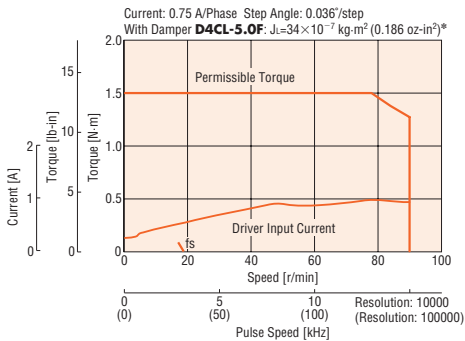

CRK543 Gear Ratio 30

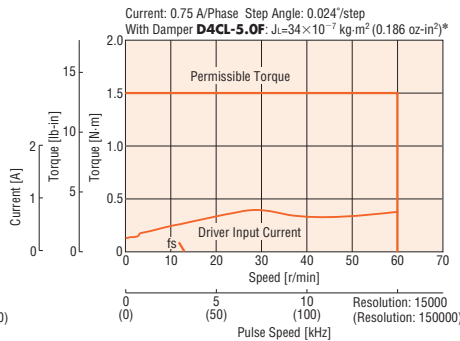

* For motors with an encoder, a load with a similar inertia should be attached.

● The pulse input circuit responds to approximately 500 kHz with a pulse duty of 50%.

Note

● Pay attention to heat dissipation from motor as there will be a considerable amount of heat under certain conditions. Be sure to keep the temperature of the motor case under 100°C (212°F). [Under 75°C (167°F) is required to comply with UL or CSA Standards as the motor is recognized as Thermal Class 105 (A).]

Introduction
 DC Input Motor & Driver
 0.36° / Geared / CRK
 0.72° / Geared / RBK
 0.9° / 1.8° / Geared / PK
 0.36° / Geared / ASX
 0.36° / Geared / CRK
 0.36° / Geared / CMK
 1.8° / Geared / RBK
 0.36° / Geared / PK
 0.72° / Geared / PK
 0.9° / Geared / PK
 1.8° / Geared / PK
 Motor Only
 Geared / PK
 Controllers / SCX10 / EMP400 / SG8030J
 Accessories

TH Geared Type Motor Frame Size 60 mm (2.36 in.)

Specifications RoHS



Model	Pulse Input Package	Single Shaft	CRK564AP-T3.6	CRK564AP-T7.2	CRK564AP-T10	CRK564AP-T20	CRK564AP-T30
	Built-In Controller Package	Double Shaft	CRK564BP-T3.6	CRK564BP-T7.2	CRK564BP-T10	CRK564BP-T20	CRK564BP-T30
		With Encoder*2	CRK564APR27T3.6	CRK564APR27T7.2	CRK564APR27T10	CRK564APR27T20	CRK564APR27T30
		Single Shaft	CRK564AKP-T3.6	CRK564AKP-T7.2	CRK564AKP-T10	CRK564AKP-T20	CRK564AKP-T30
		Double Shaft	CRK564BKP-T3.6	CRK564BKP-T7.2	CRK564BKP-T10	CRK564BKP-T20	CRK564BKP-T30
		With Encoder*2	CRK564RKPT3.6	CRK564RKPT7.2	CRK564RKPT10	CRK564RKPT20	CRK564RKPT30
Maximum Holding Torque		N·m (lb·in)	1.25 (11)	2.5 (22)	3 (26)	3.5 (30)	4 (35)
Rotor Inertia		J: kg·m ² (oz·in ²)	175×10 ⁻⁷ (0.96)				
Rated Current		A/Phase	1.4				
Basic Step Angle			0.2°	0.1°	0.072°	0.036°	0.024°
Gear Ratio			3.6	7.2	10	20	30
Permissible Torque		N·m (lb·in)	1.25 (11)	2.5 (22)	3 (26)	3.5 (30)	4 (35)
Holding Torque at Motor Standstill	Power ON	N·m (lb·in)	0.75 (6.6)	1.5 (13.2)	2.1 (18.5)	3.5 (30)	4 (35)
Backlash		arc minute (degrees)	35 (0.59°)	15 (0.25°)		10 (0.17°)	
Permissible Speed Range		r/min	0~500	0~250	0~180	0~90	0~60
Power Source			24 VDC ± 10% 2.5 A				
Excitation Mode			Microstep				

*1 Certification for UL standards is only acquired on pulse input package.

*2 Encoder connection cable [0.6 m (2 ft.)] is included with the motor with encoder and driver package.

Note

● Direction of rotation of the motor and that of the gear output shaft are the same for the gear ratios 3.6, 7.2 and 10. It is the opposite for 20 and 30 gear ratios.

Speed – Torque Characteristics

CRK564 Gear Ratio 3.6

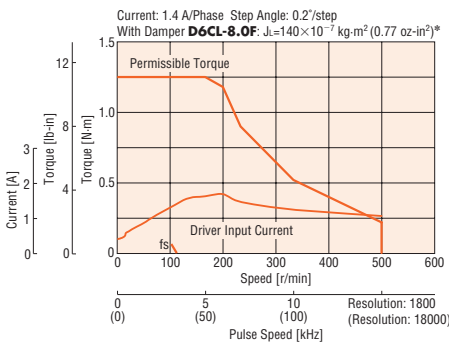

CRK564 Gear Ratio 7.2

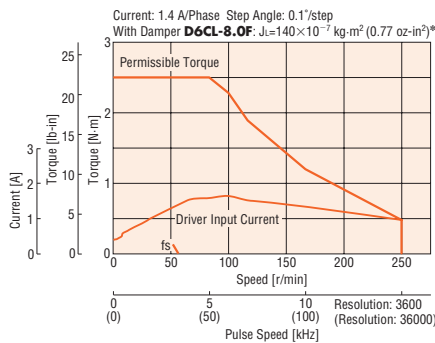

CRK564 Gear Ratio 10

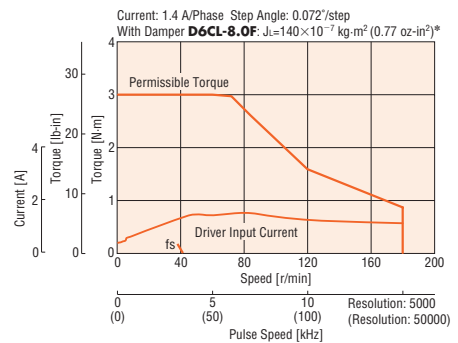

CRK564 Gear Ratio 20

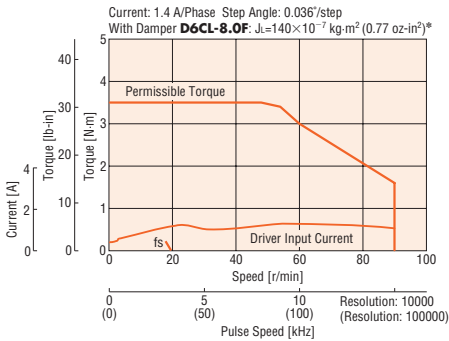

CRK564 Gear Ratio 30

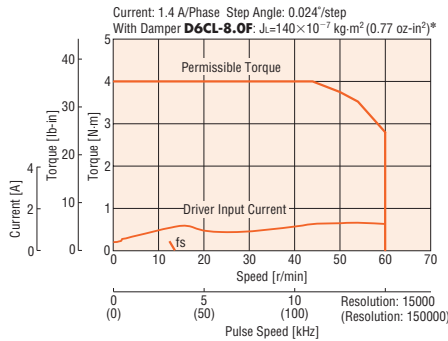

*For motors with an encoder, a load with a similar inertia should be attached.

● The pulse input circuit responds to approximately 500 kHz with a pulse duty of 50%.

Note

● Pay attention to heat dissipation from motor as there will be a considerable amount of heat under certain conditions. Be sure to keep the temperature of the motor case under 100°C (212°F). [Under 75°C (167°F) is required to comply with UL or CSA Standards as the motor is recognized as Thermal Class 105 (A).]

PS Geared Type Motor Frame Size 28 mm (1.10 in.)

Specifications RoHS



Model	Pulse Input Package	Single Shaft	CRK523PAP-PS5	CRK523PAP-PS7	CRK523PAP-PS10
	Built-In Controller Package	Double Shaft	CRK523PBP-PS5	CRK523PBP-PS7	CRK523PBP-PS10
		Single Shaft	CRK523PAKP-PS5	CRK523PAKP-PS7	CRK523PAKP-PS10
		Double Shaft	CRK523PBKP-PS5	CRK523PBKP-PS7	CRK523PBKP-PS10
Maximum Holding Torque		N·m (oz·in)	0.2 (28)	0.3 (42)	0.4 (56)
Rotor Inertia		J: kg·m ² (oz·in ²)	9×10 ⁻⁷ (0.049)		
Rated Current		A/Phase	0.35		
Basic Step Angle			0.144°	0.1°	0.072°
Gear Ratio			5	7.2	10
Permissible Torque		N·m (oz·in)	0.2 (28)	0.3 (42)	0.4 (56)
Maximum Torque		N·m (oz·in)	0.5 (71)		
Holding Torque at Motor Standstill Power ON		N·m (oz·in)	0.12 (17.0)	0.17 (24)	0.24 (34)
Backlash		arc minute (degrees)	35 (0.59)		
Permissible Speed Range		r/min	0~600	0~416	0~300
Power Supply Input			24 VDC±10% 0.7 A		
Excitation Mode			Microstep		

* Certification for UL standards is only acquired on pulse input package.

● Connection cable [0.6 m (2 ft.)] is included with the connector-coupled motor and driver package.

Note

● Direction of rotation of the motor and that of the gear output shaft are the same.

Speed – Torque Characteristics

CRK523 Gear Ratio 5

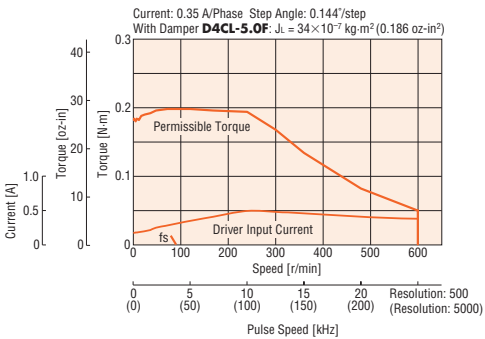

CRK523 Gear Ratio 7.2

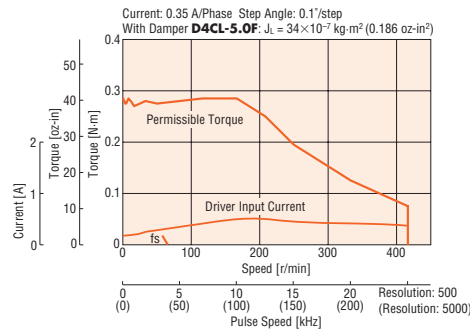

CRK523 Gear Ratio 10

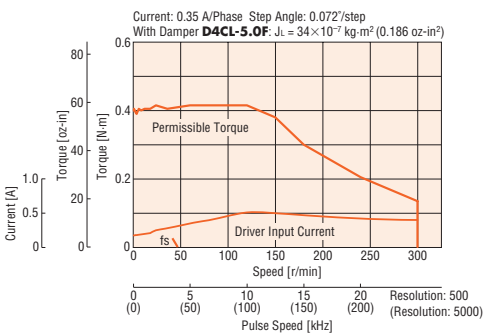

● The pulse input circuit responds to approximately 500 kHz with a pulse duty of 50%.

Note

● Pay attention to heat dissipation from motor as there will be a considerable amount of heat under certain conditions. Be sure to keep the temperature of the motor case under 100°C (212°F). [Under 75°C (167°F) is required to comply with UL or CSA Standards as the motor is recognized as Thermal Class 105 (A).]

Introduction	AC Input Motor & Driver	Motor Only
AR	AS	PK
0.36° / Geared	0.72° / Geared	0.9° / Geared
AS	UMK	PK/PV
0.36° / Geared	0.9° / 1.8°	1.8°
ASX	CRK	Geared
0.36° / Geared	0.36° / 0.72° / Geared	PK
ASX	CMK	PK
0.36° / Geared	0.9° / 1.8° / Geared	PK
ASX	RBK	PK
0.36° / Geared	1.8°	PK
ASX	PK	PK
0.36° / Geared	0.72°	PK
ASX	PK	PK
0.36° / Geared	0.9°	PK
ASX	PK	PK
0.36° / Geared	1.8°	PK
ASX	PK	PK
0.36° / Geared	Geared	Controllers
ASX	PK	SCX10 / EMP400 / SG8030J
0.36° / Geared	Accessories	
ASX		

PS Geared Type Motor Frame Size 42 mm (1.65 in.)

Specifications RoHS



Model	Pulse Input Package	Single Shaft	CRK545AP-PS5	CRK545AP-PS7	CRK545AP-PS10	CRK543AP-PS25	CRK543AP-PS36	CRK543AP-PS50
	Built-In Controller Package	Double Shaft	CRK545BP-PS5	CRK545BP-PS7	CRK545BP-PS10	CRK543BP-PS25	CRK543BP-PS36	CRK543BP-PS50
With Encoder*2		CRK545APR27PS5	CRK545APR27PS7	CRK545APR27PS10	CRK543APR27PS25	CRK543APR27PS36	CRK543APR27PS50	
Single Shaft		CRK545AKP-PS5	CRK545AKP-PS7	CRK545AKP-PS10	CRK543AKP-PS25	CRK543AKP-PS36	CRK543AKP-PS50	
		Double Shaft	CRK545BKP-PS5	CRK545BKP-PS7	CRK545BKP-PS10	CRK543BKP-PS25	CRK543BKP-PS36	CRK543BKP-PS50
		With Encoder*2	CRK545RKPPS5	CRK545RKPPS7	CRK545RKPPS10	CRK543RKPPS25	CRK543RKPPS36	CRK543RKPPS50
Maximum Holding Torque	N·m (lb·in)		1 (8.8)	1.5 (13.2)	2.5 (22)	3 (26)		
Rotor Inertia	J: kg·m ² (oz·in ²)		68×10 ⁻⁷ (0.37)			35×10 ⁻⁷ (0.191)		
Rated Current	A/Phase		0.75					
Basic Step Angle			0.144°	0.1°	0.072°	0.0288°	0.02°	0.0144°
Gear Ratio			5	7.2	10	25	36	50
Permissible Torque	N·m (lb·in)		1 (8.8)	1.5 (13.2)	2.5 (22)	3 (26)		
Maximum Torque	N·m (lb·in)		1.5 (13.2)	2 (17.7)		6 (53)		
Holding Torque at Motor Standstill	Power ON N·m (lb·in)		0.6 (5.3)	0.86 (7.6)	1.2 (10.6)	1.6 (14.1)	2.3 (20)	3 (26)
Backlash	arc minute (degrees)		25 (0.42°)					
Permissible Speed Range	r/min		0~600	0~416	0~300	0~120	0~83	0~60
Power Supply Input			24 VDC±10% 1.4 A					
Excitation Mode			Microstep					

*1 Certification for UL standards is only acquired on pulse input package.

*2 Encoder connection cable [0.6 m (2 ft.)] is included with the motor with encoder and driver package.

Note

● Direction of rotation of the motor and that of the gear output shaft are the same.

Speed – Torque Characteristics

CRK545 Gear Ratio 5

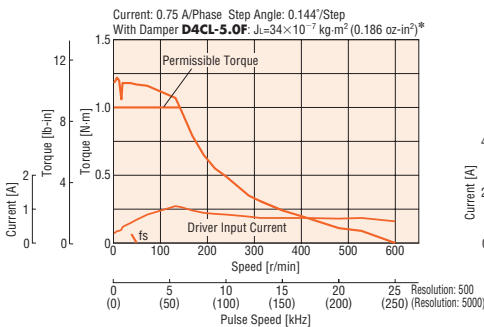

CRK545 Gear Ratio 7.2

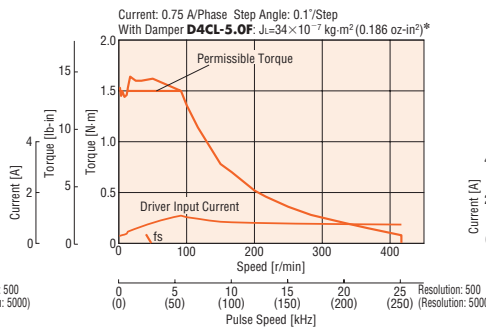

CRK545 Gear Ratio 10

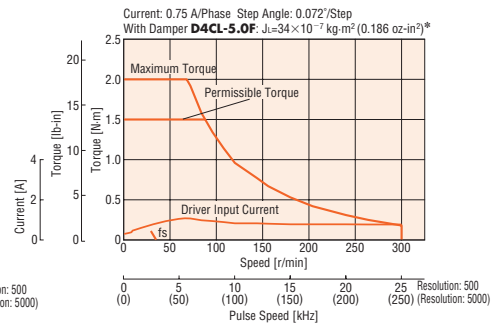

CRK543 Gear Ratio 25

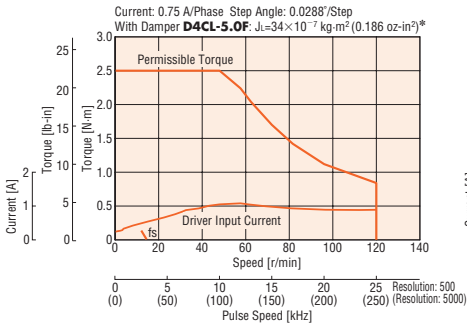

CRK543 Gear Ratio 36

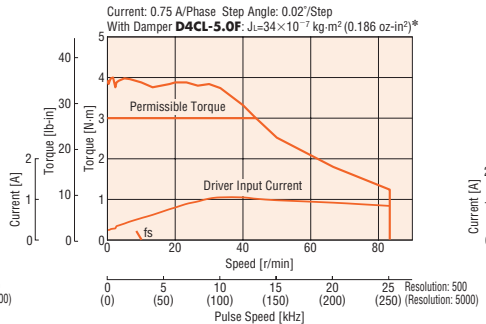

CRK543 Gear Ratio 50

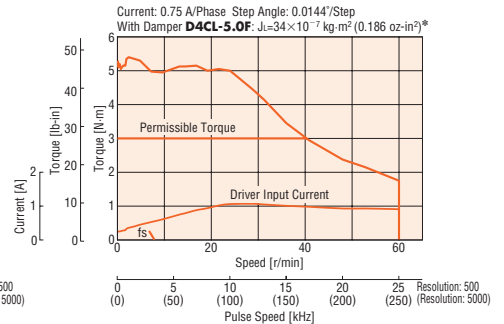

*For motors with an encoder, a load with a similar inertia should be attached.

● The pulse input circuit responds to approximately 500 kHz with a pulse duty of 50%.

Note

● Pay attention to heat dissipation from motor as there will be a considerable amount of heat under certain conditions. Be sure to keep the temperature of the motor case under 100°C (212°F).
[Under 75°C (167°F) is required to comply with UL or CSA Standards as the motor is recognized as Thermal Class 105 (A).]

PS Geared Type Motor Frame Size 60 mm (2.36 in.)

Specifications RoHS



Model	Pulse Input Package	Single Shaft	CRK566AP-PS5	CRK566AP-PS7	CRK566AP-PS10	CRK564AP-PS25	CRK564AP-PS36	CRK564AP-PS50
		Double Shaft	CRK566BP-PS5	CRK566BP-PS7	CRK566BP-PS10	CRK564BP-PS25	CRK564BP-PS36	CRK564BP-PS50
	With Encoder*2		CRK566APR27PS5	CRK566APR27PS7	CRK566APR27PS10	CRK564APR27PS25	CRK564APR27PS36	CRK564APR27PS50
Built-In Controller Package	Single Shaft	CRK566AKP-PS5	CRK566AKP-PS7	CRK566AKP-PS10	CRK564AKP-PS25	CRK564AKP-PS36	CRK564AKP-PS50	
	Double Shaft	CRK566BKP-PS5	CRK566BKP-PS7	CRK566BKP-PS10	CRK564BKP-PS25	CRK564BKP-PS36	CRK564BKP-PS50	
	With Encoder*2		CRK566RKPPS5	CRK566RKPPS7	CRK566RKPPS10	CRK564RKPPS25	CRK564RKPPS36	CRK564RKPPS50
Maximum Holding Torque	N·m (lb·in)	3.5 (30)		4 (35)	5 (44)	8 (70)		
Rotor Inertia	J: kg·m ² (oz·in ²)	280×10 ⁻⁷ (1.53)				175×10 ⁻⁷ (0.96)		
Rated Current	A/Phase	1.4						
Basic Step Angle		0.144°	0.1°	0.072°	0.0288°	0.02°	0.0144°	
Gear Ratio		5	7.2	10	25	36	50	
Permissible Torque	N·m (lb·in)	3.5 (30)		4 (35)	5 (44)	8 (70)		
Maximum Torque	N·m (lb·in)	7 (61)	9 (79)	11 (97)	16 (141)	20 (177)		
Holding Torque at Motor Standstill	Power ON N·m (lb·in)	2 (17.7)	2.9 (25)	4.1 (36)	5.2 (46)	7.5 (66)	8 (70)	
Backlash	arc minute (degrees)	15 (0.25°)						
Permissible Speed Range	r/min	0~600	0~416	0~300	0~120	0~83	0~60	
Power Supply Input		24 VDC±10%			2.5 A			
Excitation Mode		Microstep						

*1 Certification for UL standards is only acquired on pulse input package.

*2 Encoder connection cable [0.6 m (2 ft.)] is included with the motor with encoder and driver package.

Note

- Direction of rotation of the motor and that of the gear output shaft are the same.

Speed – Torque Characteristics

CRK566 Gear Ratio 5

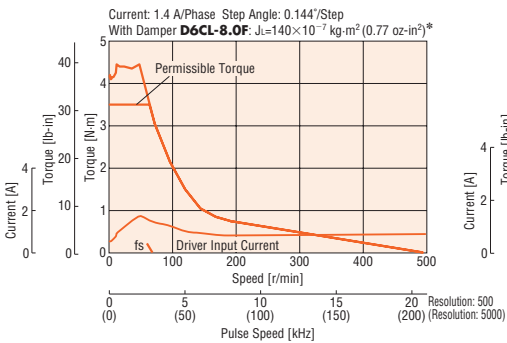

CRK566 Gear Ratio 7.2

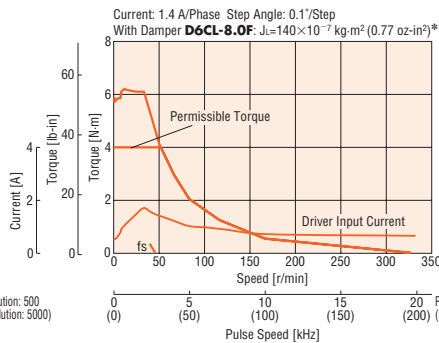

CRK566 Gear Ratio 10

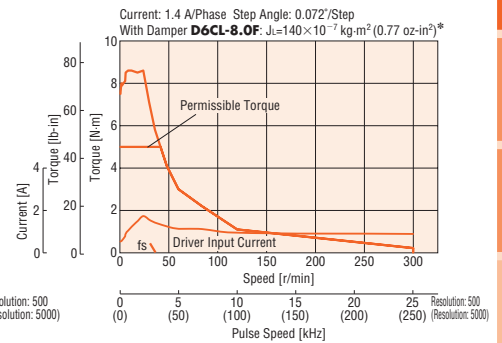

CRK564 Gear Ratio 25

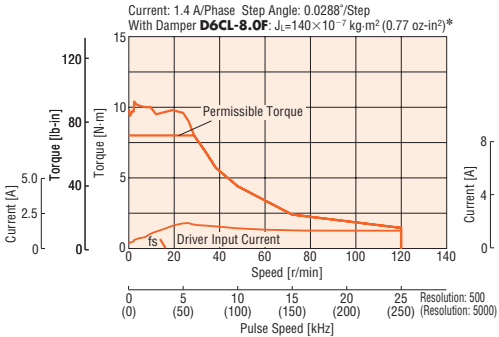

CRK564 Gear Ratio 36

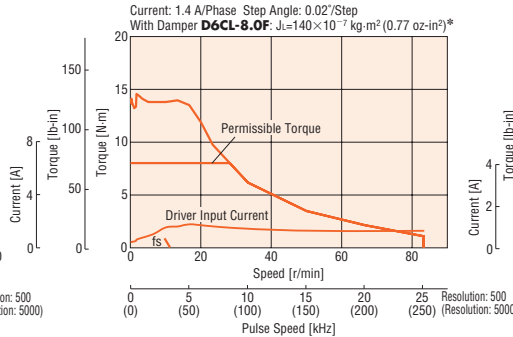

CRK564 Gear Ratio 50

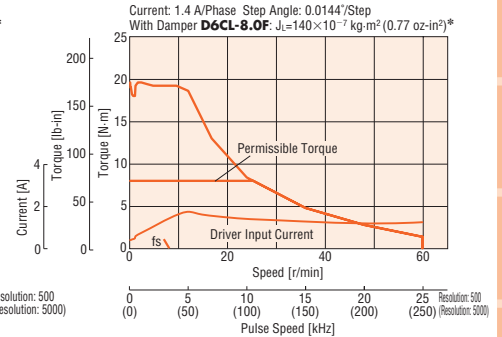

* For motors with an encoder, a load with a similar inertia should be attached.

- The pulse input circuit responds to approximately 500 kHz with a pulse duty of 50%.

Note

- Pay attention to heat dissipation from motor as there will be a considerable amount of heat under certain conditions. Be sure to keep the temperature of the motor case under 100°C (212°F).
[Under 75°C (167°F) is required to comply with UL or CSA Standards as the motor is recognized as Thermal Class 105 (A).]

Introduction
AR / G57P / Geared / 0.36° / AC Input Motor & Driver / 0.72° / Geared / 0.9°/1.8° / UMK / 0.36° / Geared / 0.36° / Geared / ASX / DC Input Motor & Driver / 0.36°/0.72° / Geared / 0.9°/1.8° / Geared / CMK / RBK / 1.8° / Geared / PK / 0.36° / PK / 0.72° / Motor Only / PK / 0.9° / PK / 1.8° / PK / PV / Geared / PK / Controllers / SCX10 / EMP400 / /SG8030J / Accessories

PN Geared Type Motor Frame Size 28 mm (1.10 in.), 42 mm (1.65 in.)

Specifications RoHS



Model	Pulse Input Package	Single Shaft	CRK523PAP-N5*	CRK523PAP-N7.2*	CRK523PAP-N10*	CRK544AP-N5	CRK544AP-N7.2	CRK544AP-N10
		Double Shaft	CRK523PBP-N5*	CRK523PBP-N7.2*	CRK523PBP-N10*	CRK544BP-N5	CRK544BP-N7.2	CRK544BP-N10
Maximum Holding Torque		N-m CRK523: oz-in/CRK544: lb-in	0.2 (28)	0.3 (42)	0.4 (56)	0.8 (7)	1.2 (10.6)	1.5 (13.2)
Rotor Inertia		J: kg-m ² (oz-in ²)	9×10 ⁻⁷ (0.049)			54×10 ⁻⁷ (0.3)		
Rated Current		A/Phase	0.35			0.75		
Basic Step Angle			0.144°	0.1°	0.072°	0.144°	0.1°	0.072°
Gear Ratio			5	7.2	10	5	7.2	10
Permissible Torque		N-m CRK523: oz-in/CRK544: lb-in	0.2 (28)	0.3 (42)	0.4 (56)	0.8 (7)	1.2 (10.6)	1.5 (13.2)
Maximum Torque		N-m CRK523: oz-in/CRK544: lb-in	0.5 (71)			1.5 (13.2)	2 (17.7)	
Holding Torque at Motor Standstill Power ON		N-m CRK523: oz-in/CRK544: lb-in	0.12 (17.0)	0.17 (24)	0.24 (34)	0.45 (3.9)	0.64 (14.5)	0.9 (7.9)
Backlash		arc minute (degrees)	3 (0.05°)			2 (0.034°)		
Permissible Speed Range		r/min	0~600	0~416	0~300	0~600	0~416	0~300
Power Source			24 VDC±10% 0.7 A			24 VDC±10% 1.4 A		
Excitation Mode			Microstep					

* Connection Cable [0.6 m (2 ft.)] is included with the connector-coupled motor and driver package.

Note

- Direction of rotation of the motor and that of the gear output shaft are the same.

Speed – Torque Characteristics

CRK523 Gear Ratio 5

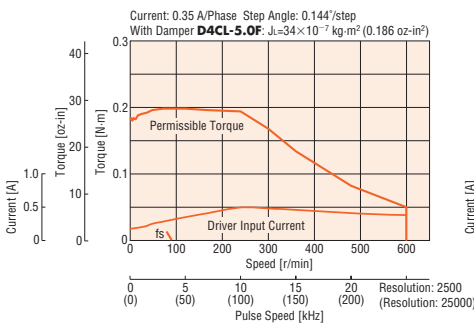

CRK523 Gear Ratio 7.2

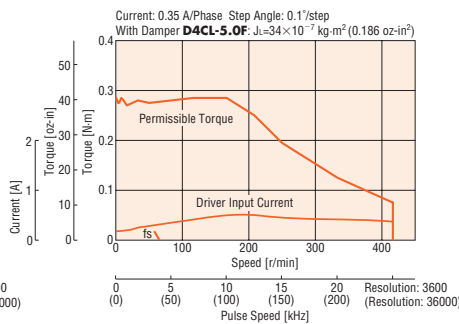

CRK523 Gear Ratio 10

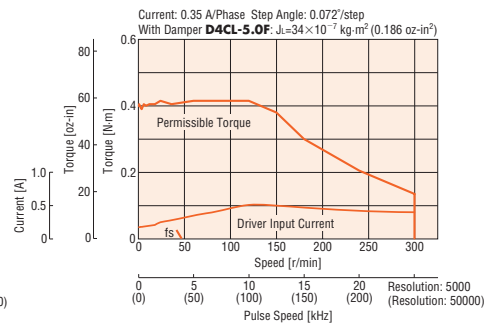

CRK544 Gear Ratio 5

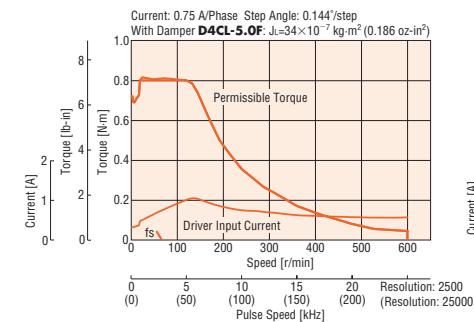

CRK544 Gear Ratio 7.2

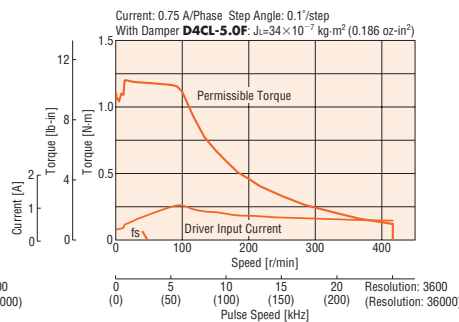

CRK544 Gear Ratio 10

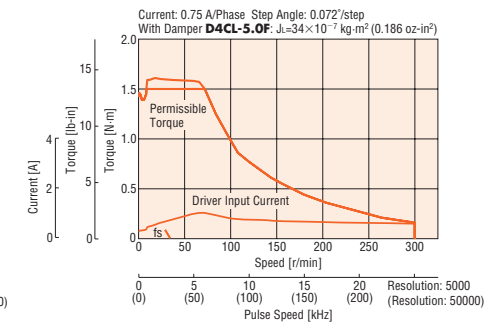

- The pulse input circuit responds to approximately 500 kHz with a pulse duty of 50%.

Note

- Pay attention to heat dissipation from motor as there will be a considerable amount of heat under certain conditions. Be sure to keep the temperature of the motor case under 100°C (212°F). [Under 75°C (167°F) is required to comply with UL or CSA Standards as the motor is recognized as Thermal Class 105 (A).]

PN Geared Type Motor Frame Size 60 mm (2.36 in.)

Specifications RoHS



Model	Pulse Input Package	Single Shaft	CRK566AP-N5	CRK566AP-N7.2	CRK566AP-N10	CRK564AP-N25	CRK564AP-N36	CRK564AP-N50
		Double Shaft	CRK566BP-N5	CRK566BP-N7.2	CRK566BP-N10	CRK564BP-N25	CRK564BP-N36	CRK564BP-N50
Maximum Holding Torque		N-m (lb-in)	3.5 (30)	4 (35)	5 (44)		8 (70)	
Rotor Inertia		J: kg-m ² (oz-in ²)	280×10 ⁻⁷ (1.53)			175×10 ⁻⁷ (0.96)		
Rated Current		A/Phase	1.4					
Basic Step Angle			0.144°	0.1°	0.072°	0.0288°	0.02°	0.0144°
Gear Ratio			5	7.2	10	25	36	50
Permissible Torque		N-m (lb-in)	3.5 (30)	4 (35)	5 (44)	8 (70)		
Maximum Torque		N-m (lb-in)	7 (61)	9 (79)	11 (97)	16 (141)	20 (177)	
Holding Torque at Motor Standstill	Power ON	N-m (lb-in)	2 (17.7)	2.9 (25)	4.1 (36)	5.2 (46)	7.5 (66)	8 (70)
Backlash		arc minute (degrees)	2 (0.034°)			3 (0.05°)		
Permissible Speed Range		r/min	0~600	0~416	0~300	0~120	0~83	0~60
Power Source			24 VDC±10% 2.5 A					
Excitation Mode			Microstep					

Note

● Direction of rotation of the motor and that of the gear output shaft are the same.

Speed – Torque Characteristics

CRK566 Gear Ratio 5

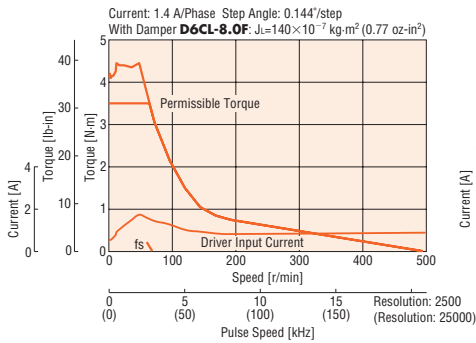

CRK566 Gear Ratio 7.2

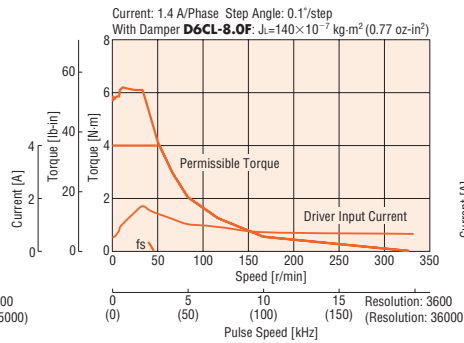

CRK566 Gear Ratio 10

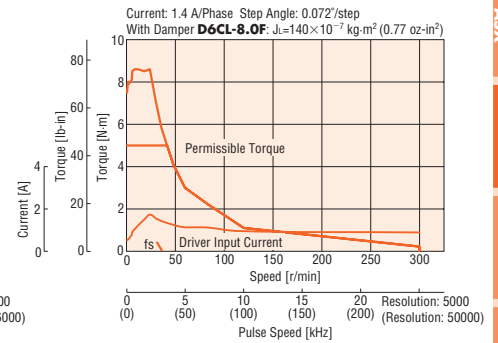

CRK564 Gear Ratio 25

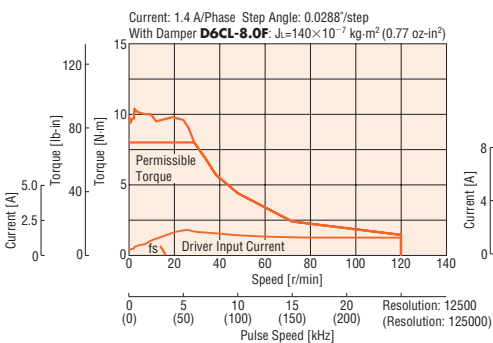

CRK564 Gear Ratio 36

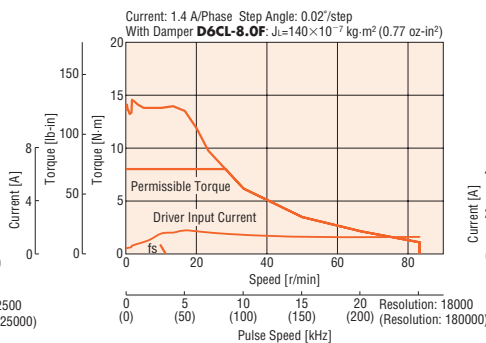

CRK564 Gear Ratio 50

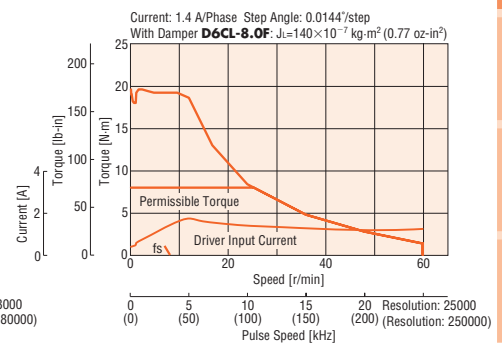

● The pulse input circuit responds to approximately 500 kHz with a pulse duty of 50%.

Note

● Pay attention to heat dissipation from motor as there will be a considerable amount of heat under certain conditions. Be sure to keep the temperature of the motor case under 100°C (212°F). [Under 75°C (167°F) is required to comply with UL or CSA Standards as the motor is recognized as Thermal Class 105 (A).]

Introduction
AC Input Motor & Driver
Geared / Geared
RK
UMK
DC Input Motor & Driver
Geared / Geared
CRK
CMK
RBK
Motor Only
PK
PK
PK
PK/PV
Geared
Controllers
SCX10
EMP400
/SG8030J
Accessories

Harmonic Geared Type Motor Frame Size 20 mm (0.79 in.), 30 mm (1.18 in.)

Specifications RoHS



Model	Pulse Input Package	Single Shaft	CRK513PAP-H50	CRK513PAP-H100	CRK523PAP-H50	CRK523PAP-H100
		Double Shaft	CRK513PBP-H50	CRK513PBP-H100	CRK523PBP-H50	CRK523PBP-H100
Built-In Controller Package	Single Shaft	CRK513PAKP-H50	CRK513PAKP-H100	CRK523PAKP-H50	CRK523PAKP-H100	
	Double Shaft	CRK513PBKP-H50	CRK513PBKP-H100	CRK523PBKP-H50	CRK523PBKP-H100	
Maximum Holding Torque		N·m (lb·in)	0.4 (3.5)	0.6 (5.3)	1.8 (15.9)	2.4 (21)
Rotor Inertia		J: kg·m ² (oz·in ²)	2.1 × 10 ⁻⁷ (0.0115)		12 × 10 ⁻⁷ (0.066)	
Rated Current		A/Phase	0.35		0.75	
Basic Step Angle			0.0144°	0.0072°	0.0144°	0.0072°
Gear Ratio			50	100	50	100
Permissible Torque		N·m (lb·in)	0.4 (3.5)	0.6 (5.3)	1.8 (15.9)	2.4 (21)
Maximum Torque		N·m (lb·in)	0.9 (7.9)	1.4 (12.3)	3.3 (29)	4.8 (42)
Holding Torque at Motor Standstill	Power ON	N·m (lb·in)	0.4 (3.5)	0.6 (5.3)	1.2 (10.6)	2.4 (21)
Lost Motion (Load Torque)		arc minute	2 max. (±0.02 N·m)	2 max. (±0.03 N·m)	1.5 max. (±0.09 N·m)	1.5 max. (±0.12 N·m)
Permissible Speed Range		r/min	0~90	0~45	0~70	0~35
Power Source			24 VDC ± 10% 0.7 A		24 VDC ± 10% 1.4 A	
Excitation Mode			Microstep			

*Certification for UL standards is only acquired on pulse input package.

● Connection cable [0.6 m (2 ft.)] is included with the connector-coupled motor and driver package.

Notes

- The inertia represents a sum of the inertia of the harmonic gear converted to a motor shaft value, and the rotor inertia.
- Direction of rotation of the motor and that of the gear output shaft are the opposite.

Speed – Torque Characteristics

CRK513 Gear Ratio 50

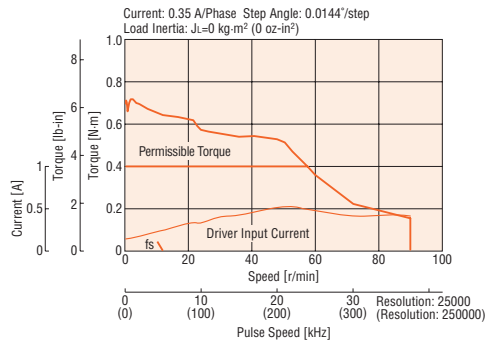

CRK513 Gear Ratio 100

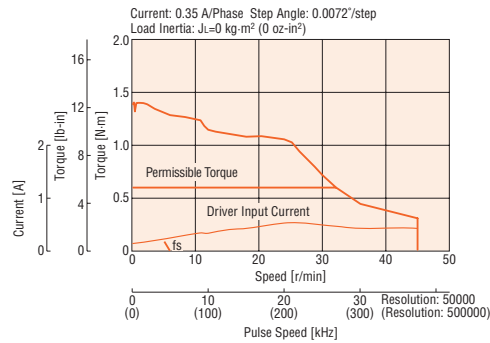

CRK523 Gear Ratio 50

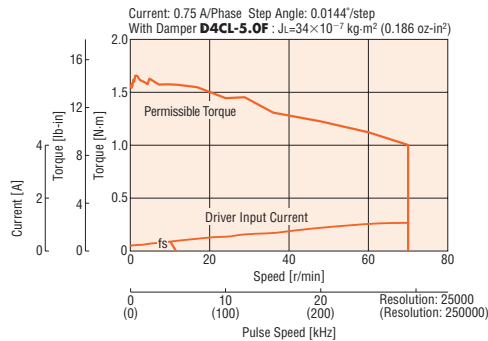

CRK523 Gear Ratio 100

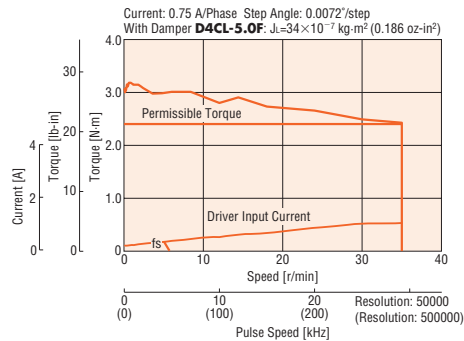

● The pulse input circuit responds to approximately 500 kHz with a pulse duty of 50%.

Notes

- Pay attention to heat dissipation from motor as there will be a considerable amount of heat under certain conditions. Be sure to keep the temperature of the motor case under 100°C (212°F). [Under 75°C (167°F) is required to comply with UL or CSA Standards as the motor is recognized as Thermal Class 105 (A).]
- In order to prevent degradation of the gear grease in harmonic gear, keep the temperature of the gear case under 70°C (158°F).

Harmonic Geared Type Motor Frame Size 42 mm (1.65 in.), 60 mm (2.36 in.)

Specifications RoHS



Model	Pulse Input Package	Single Shaft	CRK543AP-H50	CRK543AP-H100	CRK564AP-H50	CRK564AP-H100
		Double Shaft	CRK543BP-H50	CRK543BP-H100	CRK564BP-H50	CRK564BP-H100
Built-In Controller Package	With Encoder*2	Single Shaft	CRK543APR27H50	CRK543APR27H100	CRK564APR27H50	CRK564APR27H100
		Double Shaft	CRK543BKP-H50	CRK543BKP-H100	CRK564BKP-H50	CRK564BKP-H100
	With Encoder*2		CRK543RKP-H50	CRK543RKP-H100	CRK564RKP-H50	CRK564RKP-H100
Maximum Holding Torque		N·m (lb·in)	3.5 (30)	5 (44)	5.5 (48)	8 (70)
Rotor Inertia		J: kg·m ² (oz·in ²)	52 × 10 ⁻⁷ (0.28)		210 × 10 ⁻⁷ (1.15)	
Rated Current		A/Phase	0.75		1.4	
Basic Step Angle			0.0144°	0.0072°	0.0144°	0.0072°
Gear Ratio			50	100	50	100
Permissible Torque		N·m (lb·in)	3.5 (30)	5 (44)	5.5 (48)	8 (70)
Maximum Torque		N·m (lb·in)	8.3 (73)	11 (97)	18 (159)	28 (240)
Holding Torque at Motor Standstill	Power ON	N·m (lb·in)	3.2 (28)	5 (44)	5.5 (48)	8 (70)
Lost Motion (Load Torque)		arc minute	1.5 max. (±0.16 N·m)	1.5 max. (±0.2 N·m)	0.7 max. (±0.28 N·m)	0.7 max. (±0.39 N·m)
Permissible Speed Range		r/min	0~70	0~35	0~70	0~35
Power Source			24 VDC ± 10%	1.4 A	24 VDC ± 10%	2.5 A
Excitation Mode			Microstep			

*1 Certification for UL standards is only acquired on pulse input package.

*2 Encoder connection cable [0.6 m (2 ft.)] is included with the motor with encoder and driver package.

Notes

- The inertia represents a sum of the inertia of the harmonic gear converted to a motor shaft value, and the rotor inertia.
- Direction of rotation of the motor and that of the gear output shaft are the opposite.

Speed – Torque Characteristics

CRK543 Gear Ratio 50

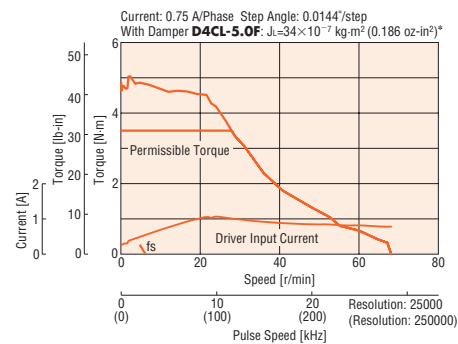

CRK543 Gear Ratio 100

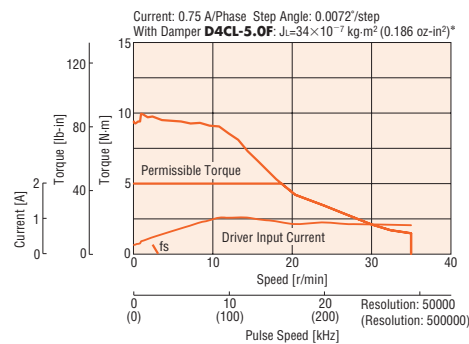

CRK564 Gear Ratio 50

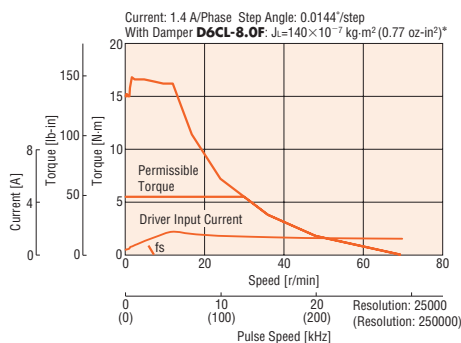

CRK564 Gear Ratio 100

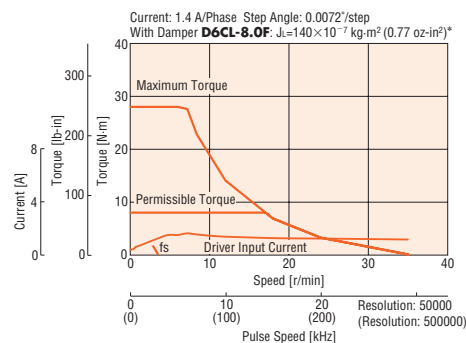

* For motors with an encoder, a load with a similar inertia should be attached.

- The pulse input circuit responds to approximately 500 kHz with a pulse duty of 50%.

Notes

- Pay attention to heat dissipation from motor as there will be a considerable amount of heat under certain conditions. Be sure to keep the temperature of the motor case under 100°C (212°F). [Under 75°C (167°F) is required to comply with UL or CSA Standards as the motor is recognized as Thermal Class 105 (A).]
- In order to prevent degradation of the gear grease in harmonic gear, keep the temperature of the gear case under 70°C (158°F).

Introduction
 DC Input Motor & Driver
 0.36° / Geared / 0.72° / Geared
 0.9°/1.8°
 0.36° / Geared / 0.72° / Geared
 0.36° / Geared / 0.72° / Geared
 0.9°/1.8° / Geared
 1.8° / Geared
 Motor Only
 0.9° / Geared
 1.8° / Geared
 0.72° / Geared
 0.9° / Geared
 1.8° / Geared
 Controllers
 SCX10 / EMP400 / SG80301
 Accessories

Driver Specifications

Pulse Input Type

Input Signals	Input Mode	Photocoupler input, Input resistance: 220 Ω, Input current: 7~20 mA Photocoupler ON: +4.5~5.25 V, Photocoupler OFF: 0~+1 V (Voltage between terminals)
	Pulse Signal (CW Pulse Signal)	Operation command pulse signal (CW direction operation command pulse signal when in 2-pulse input mode), Negative logic pulse input Pulse width: 1 μs minimum, Pulse rise/fall: 2 μs maximum, Pulse duty: 50% and below Motor moves one step when the pulse input is switched from photocoupler ON to OFF. Maximum input pulse frequency: 500 kHz (When the pulse duty is 50%)
	Rotation Direction Signal (CCW Pulse Signal)	Rotation direction signal, Photocoupler ON: CW, Photocoupler OFF: CCW (CCW direction operation command pulse signal when in 2-pulse input mode, Negative logic pulse input) Pulse width: 1 μs minimum, Pulse rise/fall: 2 μs maximum, Pulse duty: 50% and below Motor moves one step when the pulse input is switched from photocoupler ON to OFF. Maximum input pulse frequency: 500 kHz (When the pulse duty is 50%)
	All Windings Off Signal	When in the "photocoupler ON" state, the output current to the motor is cut off and the motor shaft can be rotated manually. When in the "photocoupler OFF" state, the current is supplied to the motor.
	Step Angle Select Signal	Step angle specified by DATA1 when the photocoupler is OFF, Step angle specified by DATA2 when the photocoupler is ON
	Automatic Current Cutback Release Signal	When in the "photocoupler ON" state, the automatic current cutback function will not be activated even after the motor stops. When in the "photocoupler OFF" state, the automatic current cutback function will be activated after the motor stops (after approx. 100 msec).
Output Signal	Output Mode	Photocoupler, Open-collector output External use condition: 24 VDC maximum, 10 mA maximum
	Excitation Timing Signal	The signal is output every time the excitation sequence returns to the initial stage "0." (Photocoupler: ON) 0.72°/step [Microsteps/step: 1 (Resolution: 500)]: Signal is output every 10 pulses. 0.072°/step [Microsteps/step: 10 (Resolution: 5000)]: Signal is output every 100 pulses. • Step Angle 0.36° High-Torque Type 0.36°/step [Microsteps/step: 1 (Resolution: 1000)]: Signal is output every 20 pulses. 0.036°/step [Microsteps/step: 10 (Resolution: 10000)]: Signal is output every 200 pulses.
Functions	Automatic current cutback, Step angle select, Pulse input mode switch, Smooth drive, All windings off, Excitation timing	
Cooling Method	Natural ventilation	

Built-In Controller Type

User Programs	Number of Program	64 maximum
	Maximum Program Size	1.6 kB total for compiled 4.2 kB total (text and compiled)
	Input Method	ASCII commands via RS-485
Motion Profile	Frequency	1~500 000 pps (1 step increments)
	Positioning Range	+8 388 607 to -8 388 607 steps
	Acceleration/Deceleration Range	1~1 000 000 ms (linear ramp)
Operating Modes	Relative Positioning	Available
	Absolute Positioning	Available
	Linked Motion	4 linked motion, maximum
	Continuous Operation	Available
	Return to Mechanical Home Operation	Available
	Return to Electrical Home Operation	Available
	Speed Change on the Fly	Available in continuous operation
RS-485 Communication	Electrical Characteristics	In conformance with EIA-485 Use a twisted pair cable (TIA/EIA-568B CAT5e or higher is recommended) and keep the total wiring distance including extension to 50 m (164 ft.) or less.
	Transmission Mode	Half duplex
	Baud Rate	Selectable from 9600 bps, 19200 bps, 38400 bps, 57600 bps, 115200 bps by SW2
	Physical Layer	Asynchronous mode (8 bits, 1 stop bit, no parity)
	Protocol	TTY (CR+LF) 9-byte fixed frame length, binary transfer
	Number of Multi-Dropped Devices	Up to 16 drivers can be connected to one programmable controller (master device).
Input Signals	Dedicated	Photocoupler Input, Input voltage: 24 VDC (START, ALMCLR, CROFF, ABORT, HOME, PSTOP, SENSOR, +LS, -LS, HOMES, SLT)
	Encoder	Line Driver Input 26C231 equivalent (A, B, INDEX)
	General Purpose	Photocoupler Input, Input voltage: 24 VDC (IN1~IN6)
Output Signals	Dedicated	Photocoupler, Open-collector output External use condition: 24 VDC maximum, 20 mA maximum (MOVE, ALM)
	General Purpose	Photocoupler, Open-collector output External use condition: 24 VDC maximum, 20 mA maximum (OUT1~OUT4)
	Pulse, Direction	Line driver output 26C231 equivalent (PLS-OUT, DIR-OUT)

General Specifications

Item	Motor	Driver	
		Pulse Input Package	Built-In Controller Package
Thermal Class	130 (B) [Recognized as 105 (A) by UL Standards]		-
Insulation Resistance	100 MΩ or more when 500 VDC megger is applied between the windings and the case under normal ambient temperature and humidity.	-	100 MΩ or more when 500 VDC megger is applied between the following places under normal ambient temperature and humidity: • FG terminals – Power input terminal
Dielectric Strength	Sufficient to withstand 1.5 kVAC* at 50 Hz or 60 Hz applied between the windings and the case for 1 minute under normal ambient temperature and humidity. *1.0 kVAC for CRK54□ 0.5 kVAC for CRK513P, CRK52□PM, CRK52□P, CRK54□PM, CRK54□P	-	Sufficient to withstand the following for 1 minute under normal temperature and humidity: • FG terminals – Power input terminal 500 VAC 50 Hz or 60 Hz
Operating Environment	Ambient Temperature	-10~+50°C (+14~+122°F) (non-freezing): High-torque type, Standard type, TH, PS, PN geared type 0~+40°C (+32~+104°F) (non-freezing): Harmonic geared type	0~+40°C (+32~+104°F) (non-freezing)
	Ambient Humidity	85% or less (non-condensing)	
	Atmosphere	No corrosive gases, dust, water or oil	
Temperature Rise	Temperature rise of the windings are 80°C (144°F) or less measured by the resistance change method. (at rated current, at standstill, five phases energized)		-
Stop Position Accuracy*1	±3 arc minutes (±0.05°), CRK513P : ±10 arc minutes (±0.17°) Step Angle 0.36° High-Torque Type: ±2 arc minutes (±0.034°)		-
Shaft Runout	0.05 mm (0.002 in.) T.I.R.*4		-
Radial Play*2	0.025 mm (0.001 in.) maximum of 5 N (1.12 lb.)		-
Axial Play*3	0.075 mm (0.003 in.) maximum of 10 N (2.2 lb.)		-
Concentricity	0.075 mm (0.003 in.) T.I.R.*4		-
Perpendicularity	0.075 mm (0.003 in.) T.I.R.*4		-

*1 This value is for full step under no load. (The value changes with the size of the load.)

*2 Radial Play: Displacement in shaft position in the radial direction, when a 5 N (1.12 lb.) load is applied in the vertical direction to the tip of the motor's shaft.

*3 Axial Play: Displacement in shaft position in the axial direction, when a 10 N (2.2 lb.) load is applied to the motor's shaft in the axial direction.

*4 T.I.R. (Total Indicator Reading): The total dial gauge reading when the measurement section is rotated one revolution centered on the reference axis center.

Note

- Do not measure insulation resistance or perform the dielectric strength test while the motor and driver are connected.

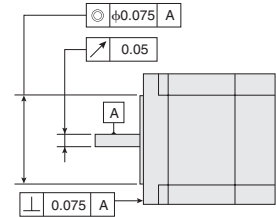

Encoder Specifications

→ Page A-17

Permissible Overhung Load and Permissible Thrust Load

→ Page A-14

Introduction	
AC Input Motor & Driver	0.36° / Geared / CRK513P, CRK52□PM, CRK52□P, CRK54□PM, CRK54□P
DC Input Motor & Driver	0.72° / Geared / RK
	0.9° / 1.8° / Geared / UMK
	0.36° / Geared / AR
	0.36° / Geared / ASX
	0.36° / 0.72° / Geared / CRK
	0.9° / 1.8° / Geared / CMK
	1.8° / Geared / RBK
Motor Only	0.36° / Geared / PK
	0.72° / Geared / PK
	0.9° / Geared / PK
	1.8° / Geared / PK/PV
	Geared / PK
Controllers	SCX10 / EMP400 / SG8030J
Accessories	

Dimensions Unit = mm (in.)

The dimensions of a motor with an encoder can be found on page A-19 or at www.orientalmotor.com.

● Motor

◇ Step Angle 0.72° High-Torque Type

Motor Frame Size 20 mm (0.79 in.)

Model		Motor Model	Mass kg (lb.)	DXF
Pulse Input Package	Built-In Controller Package			
CRK513PAP	CRK513PAKP	PK513PA	0.05 (0.11)	B316
CRK513PBP	CRK513PBKP	PK513PB		

Connection Cable of 0.6 m (2 ft.) is included with the package.

UL Style 3265, AWG24

If you are purchasing only a motor for maintenance purpose, etc., the connection cable and connector will not be supplied. They must be purchased separately.

→ Page A-404

● Applicable Connector

Connector housing: 51065-0500 (MOLEX)

Contact: 50212-8100 (MOLEX)

Crimp tool: 57176-5000 (MOLEX)

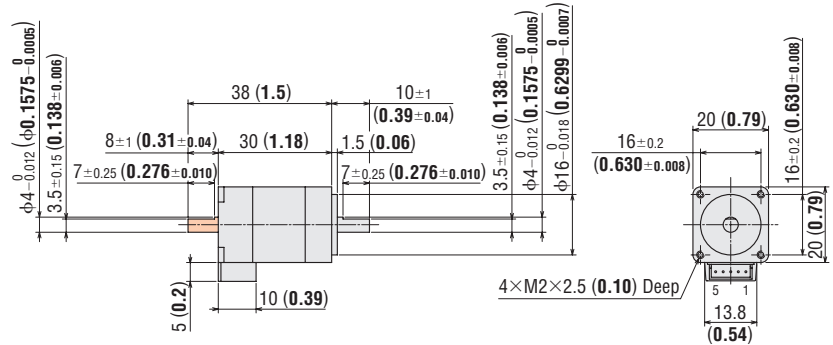

◇ Step Angle 0.36°, 0.72° High-Torque Type

Motor Frame Size 28 mm (1.10 in.)

Model		Motor Model	L1	L2	Mass kg (lb.)	DXF
Pulse Input Package	Built-In Controller Package					
CRK523P□AP	CRK523P□AKP	PK523P□A	32 (1.26)	—	0.11 (0.24)	B359
CRK523P□BP	CRK523P□BKP	PK523P□B		42 (1.65)		
CRK524PMAP	CRK524PMAKP	PK524PMA	40 (1.57)	—	0.15 (0.33)	B372
CRK524PMBP	CRK524PMBKP	PK524PMB		50 (1.97)		
CRK525P□AP	CRK525P□AKP	PK525P□A	51.5 (2.03)	—	0.2 (0.44)	B360
CRK525P□BP	CRK525P□BKP	PK525P□B		61.5 (2.42)		

● Enter **M** in the box (□) within the model name in the case of step angle 0.36° type.

Connection Cable of 0.6 m (2 ft.) is included with the package.

UL Style 3265, AWG24

If you are purchasing only a motor for maintenance purpose, etc., the connection cable and connector will not be supplied. They must be purchased separately.

→ Page A-404

● Applicable Connector

Connector housing: 51065-0500 (MOLEX)

Contact: 50212-8100 (MOLEX)

Crimp tool: 57176-5000 (MOLEX)

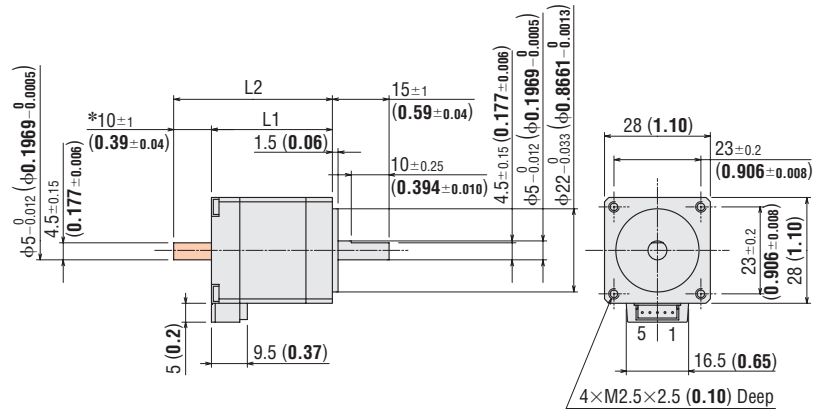

*The length of machining on the double shaft model is 10 ± 0.25 (0.394 ± 0.010).

● These dimensions are for the double shaft models. For the single shaft models, ignore the orange (■) areas.

● The dimensions of a motor with an encoder can be found on page A-19 or at www.orientalmotor.com.

Motor Frame Size 42 mm (1.65 in.)

Model		Motor Model	L1	L2	Mass kg (lb.)	DXF
Pulse Input Package	Built-In Controller Package					
CRK544P□AP	CRK544P□AKP	PK544P□A	39 (1.54)	—	0.3 (0.66)	B337
CRK544P□BP	CRK544P□BKP	PK544P□B		54 (2.13)		
CRK546P□AP	CRK546P□AKP	PK546P□A	59 (2.32)	—	0.5 (1.1)	B338
CRK546P□BP	CRK546P□BKP	PK546P□B		74 (2.91)		

● Enter **M** in the box (□) within the model name in the case of step angle 0.36° type.
 Connection Cable of 0.6 m (2 ft.) is included with the package.

UL Style 3265, AWG22

If you are purchasing only a motor for maintenance purpose, etc., the connection cable and connector will not be supplied. They must be purchased separately.

→ Page A-404

● Applicable Connector

Connector housing: 51103-0500 (MOLEX)

Contact: 50351-8100 (MOLEX)

Crimp tool: 57295-5000 (MOLEX)

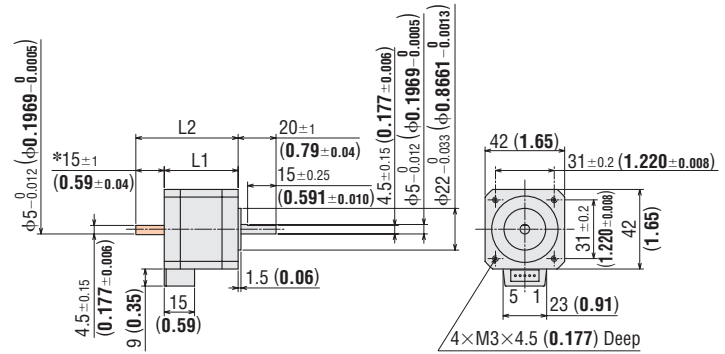

*The length of machining on the double shaft model is $15_{\pm 0.25}$ (0.591 ± 0.010).

◇ Step Angle 0.36° High-Torque Type

Motor Frame Size 60 mm (2.36 in.)

Model		Motor Model	L1	L2	L3	ϕD	Mass kg (lb.)	DXF
Pulse Input Package	Built-In Controller Package							
CRK564PMAP	CRK564PMAKP	PK564PMA	46.5 (1.83)	—	7.5 ± 0.15 (0.295 ± 0.006)	$8_{-0.015}^0$ (0.3150 ± 0.0006)	0.65 (1.43)	B373
CRK564PMBP	CRK564PMBKP	PK564PMB		69.5 (2.74)				
CRK566PMAP	CRK566PMAKP	PK566PMA	56 (2.20)	—	79 (3.11)	$10_{-0.015}^0$ (0.3937 ± 0.0006)	0.87 (1.91)	B374
CRK566PMBP	CRK566PMBKP	PK566PMB		79 (3.11)				
CRK569PMAP	CRK569PMAKP	PK569PMA	87 (3.43)	—	110 (4.33)	$10_{-0.015}^0$ (0.3937 ± 0.0006)	1.5 (3.3)	B375
CRK569PMBP	CRK569PMBKP	PK569PMB		110 (4.33)				

Connection Cable of 0.6 m (2 ft.) is included with the package.

UL Style 3266, AWG22

If you are purchasing only a motor for maintenance purpose, etc., the connection cable and connector will not be supplied. They must be purchased separately.

→ Page A-404

● Applicable Connector

Connector housing: 51144-0500 (MOLEX)

Contact: 50539-8100 (MOLEX)

Crimp tool: 57189-5000 (MOLEX)

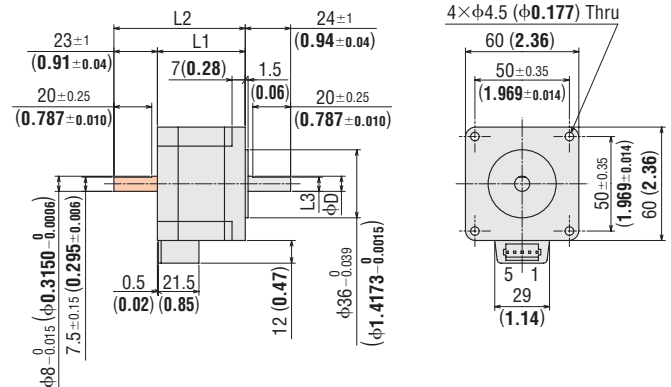

● These dimensions are for the double shaft models. For the single shaft models, ignore the orange (■) areas.
 ● The dimensions of a motor with an encoder can be found on page A-19 or at www.orientalmotor.com.

◇ Step Angle 0.72° Standard Type

Motor Frame Size 42 mm (1.65 in.)

Model		Motor Model	L1	L2	Mass kg (lb.)	DXF
Pulse Input Package	Built-In Controller Package					
CRK543AP	CRK543AKP	PK543NAW	33 (1.30)	—	0.21 (0.46)	B068
CRK543BP	CRK543BKP	PK543NBW		48 (1.89)		
CRK544AP	CRK544AKP	PK544NAW	39 (1.54)	—	0.27 (0.59)	B069
CRK544BP	CRK544BKP	PK544NBW		54 (2.13)		
CRK545AP	CRK545AKP	PK545NAW	47 (1.85)	—	0.35 (0.77)	B070
CRK545BP	CRK545BKP	PK545NBW		62 (2.44)		

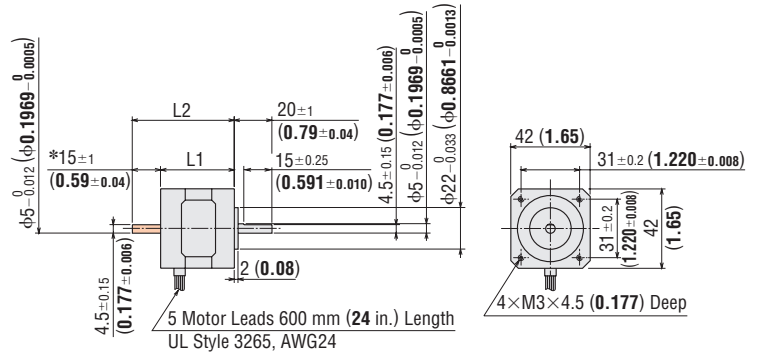

*The length of machining on the double shaft model is 15 ± 0.25 (0.591 ± 0.010).

Motor Frame Size 60 mm (2.36 in.)

Model		Motor Model	L1	L2	Mass kg (lb.)	DXF
Pulse Input Package	Built-In Controller Package					
CRK564AP	CRK564AKP	PK564NAW	46.5 (1.83)	—	0.6 (1.32)	B071
CRK564BP	CRK564BKP	PK564NBW		69.5 (2.74)		
CRK566AP	CRK566AKP	PK566NAW	57.5 (2.26)	—	0.8 (1.76)	B072
CRK566BP	CRK566BKP	PK566NBW		80.5 (3.17)		
CRK569AP	CRK569AKP	PK569NAW	87 (3.43)	—	1.3 (2.9)	B073
CRK569BP	CRK569BKP	PK569NBW		110 (4.33)		

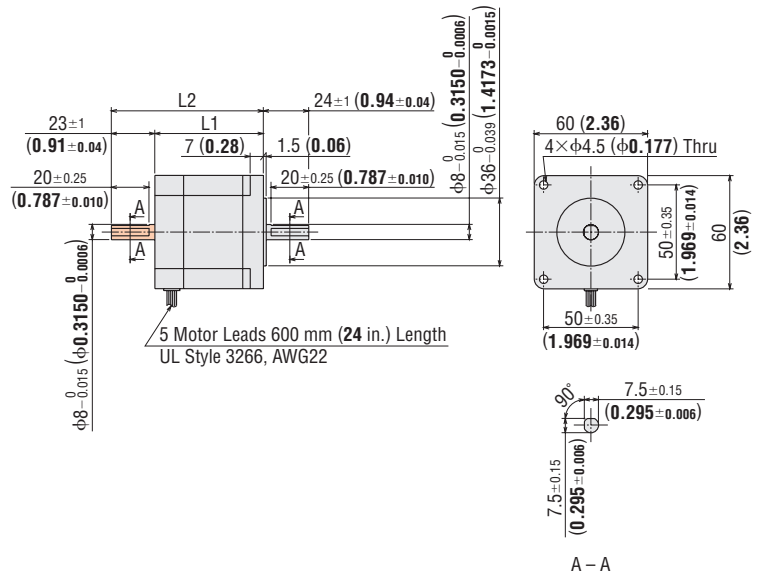

- These dimensions are for the double shaft models. For the single shaft models, ignore the orange () areas.
- The dimensions of a motor with an encoder can be found on page A-19 or at www.orientalmotor.com.

**0.36°/0.72° Stepping Motor and Driver Package
CRK Series**

Motor Frame Size 60 mm (2.36 in.)

Model		Motor Model	Gear Ratio	Mass kg (lb.)	DXF
Pulse Input Package	Built-In Controller Package				
CRK564AP-T <input type="checkbox"/>	CRK564AKP-T <input type="checkbox"/>	PK564AW-T <input type="checkbox"/>	3.6, 7.2, 10, 20, 30	0.95 (2.1)	B187
CRK564BP-T <input type="checkbox"/>	CRK564BKP-T <input type="checkbox"/>	PK564BW-T <input type="checkbox"/>			

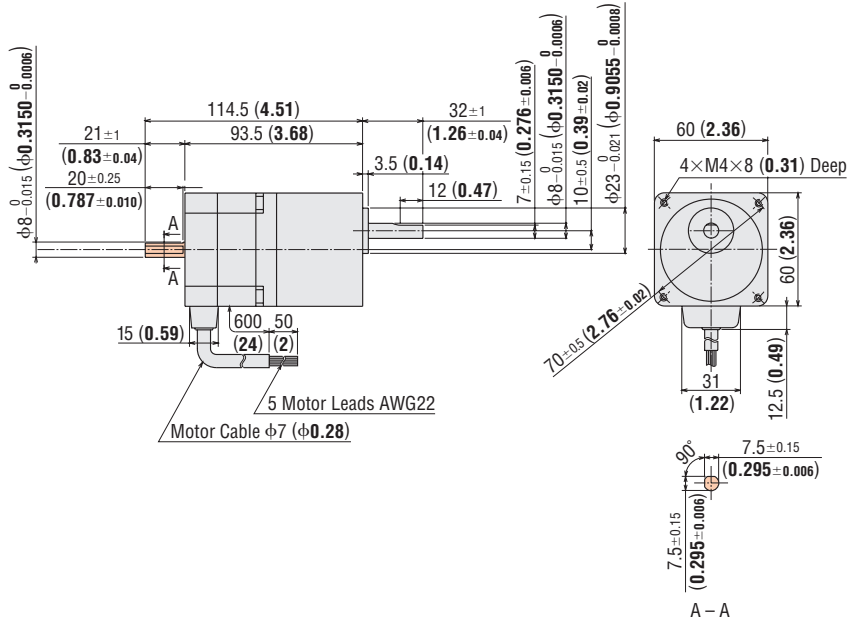

◇ PS Geared Type

Motor Frame Size 28 mm (1.10 in.)

Model		Motor Model	Gear Ratio	Mass kg (lb.)	DXF
Pulse Input Package	Built-In Controller Package				
CRK523PAP-PS <input type="checkbox"/>	CRK523PAKP-PS <input type="checkbox"/>	PK523PA-PS <input type="checkbox"/>	5, 7.2, 10	0.22 (7.8)	B684
CRK523PBP-PS <input type="checkbox"/>	CRK523PBKP-PS <input type="checkbox"/>	PK523PB-PS <input type="checkbox"/>			

Connection Cable of 0.6 m (2 ft.) is included with the package.
UL Style 3265, AWG24

If you are purchasing only a motor for maintenance purpose, etc., the connection cable and connector will not be supplied. They must be purchased separately.

→ Page A-404

- Applicable Connector
Connector housing: 51065-0500 (MOLEX)
Contact: 50212-8100 (MOLEX)
Crimp tool: 57176-5000 (MOLEX)

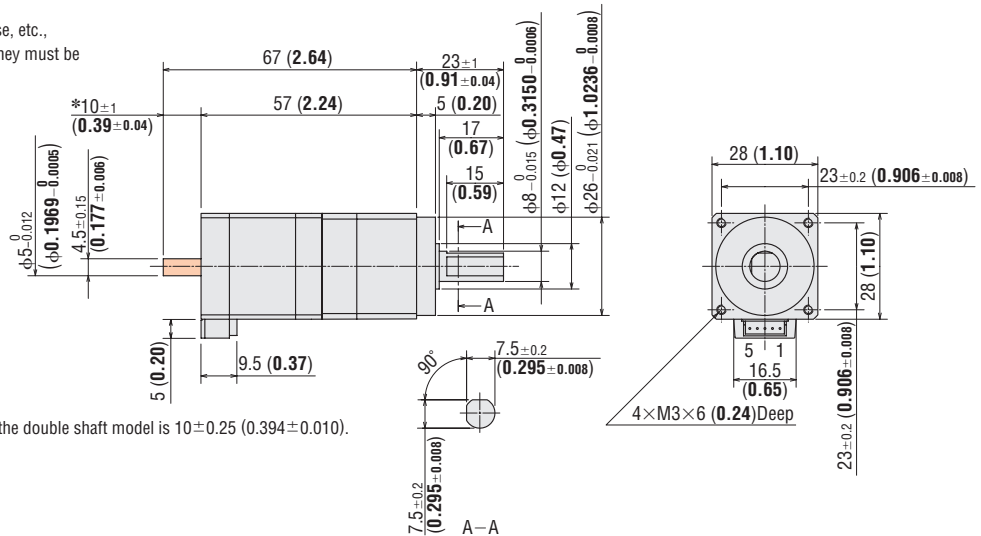

- A number indicating the gear ratio is entered where the box (□) is located within the product name.
- These dimensions are for the double shaft models. For the single shaft models, ignore the orange (■) areas.
- The dimensions of a motor with an encoder can be found on page A-19 or at www.orientalmotor.com.

Motor Frame Size 42 mm (1.65 in.)

Model		Motor Model	Gear Ratio	L1	L2	Mass kg (lb.)	DXF
Pulse Input Package	Built-In Controller Package						
CRK545AP-PS <input type="checkbox"/>	CRK545AKP-PS <input type="checkbox"/>	PK545AW-PS <input type="checkbox"/>	5, 7.2, 10	74.5 (2.93)	-	0.58 (1.28)	B678
CRK545BP-PS <input type="checkbox"/>	CRK545BKP-PS <input type="checkbox"/>	PK545BW-PS <input type="checkbox"/>			89.5 (3.52)		
CRK543AP-PS <input type="checkbox"/>	CRK543AKP-PS <input type="checkbox"/>	PK543AW-PS <input type="checkbox"/>	25, 36, 50	84 (3.31)	-	0.59 (1.30)	B679
CRK543BP-PS <input type="checkbox"/>	CRK543BKP-PS <input type="checkbox"/>	PK543BW-PS <input type="checkbox"/>			99 (3.90)		

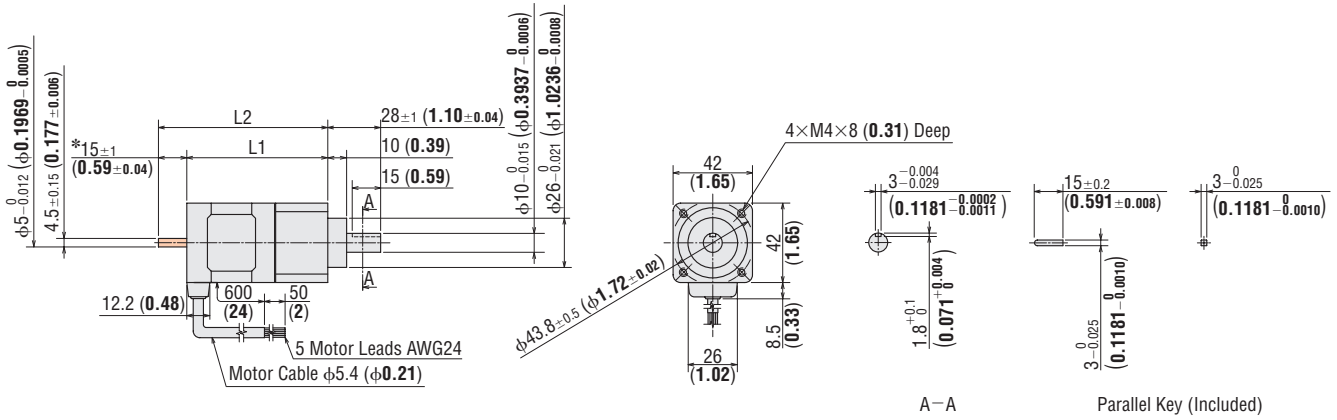

*The length of machining on the double shaft model is 15 ± 0.25 (0.591 ± 0.010).

Motor Frame Size 60 mm (2.36 in.)

Model		Motor Model	Gear Ratio	L1	L2	Mass kg (lb.)	DXF
Pulse Input Package	Built-In Controller Package						
CRK566AP-PS <input type="checkbox"/>	CRK566AKP-PS <input type="checkbox"/>	PK566AW-PS <input type="checkbox"/>	5, 7.2, 10	91.5 (3.60)	-	1.3 (2.9)	B685
CRK566BP-PS <input type="checkbox"/>	CRK566BKP-PS <input type="checkbox"/>	PK566BW-PS <input type="checkbox"/>			112.5 (4.43)		
CRK564AP-PS <input type="checkbox"/>	CRK564AKP-PS <input type="checkbox"/>	PK564AW-PS <input type="checkbox"/>	25, 36, 50	101 (3.98)	-	1.4 (3.1)	B686
CRK564BP-PS <input type="checkbox"/>	CRK564BKP-PS <input type="checkbox"/>	PK564BW-PS <input type="checkbox"/>			122 (4.80)		

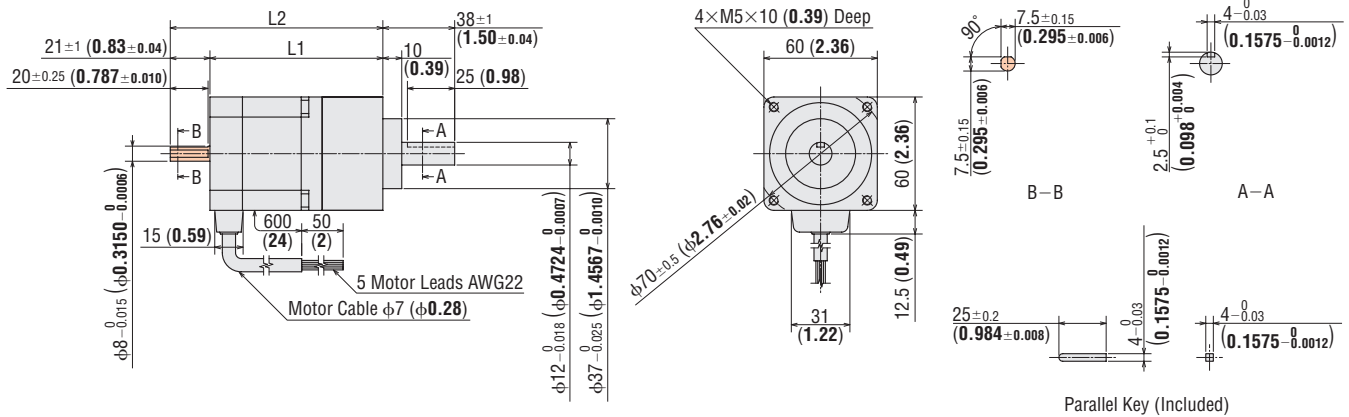

- A number indicating the gear ratio is entered where the box (□) is located within the product name.
- These dimensions are for the double shaft models. For the single shaft models, ignore the orange (■) areas.
- The dimensions of a motor with an encoder can be found on page A-19 or at www.orientalmotor.com.

◆ PN Geared Type

Motor Frame Size 28 mm (1.10 in.)

Model	Motor Model	Gear Ratio	Mass kg (lb.)	DXF
CRK523PAP-N□	PK523PA-N□	5, 7.2, 10	0.25 (0.55)	B362
CRK523PBP-N□	PK523PB-N□			

Connection Cable of 0.6 m (2 ft.) is included with the package.
UL Style 3265, AWG24

If you are purchasing only a motor for maintenance purpose, etc., the connection cable and connector will not be supplied. They must be purchased separately.

→ Page A-404

● Applicable Connector

Connector housing: 51065-0500 (MOLEX)
Contact: 50212-8100 (MOLEX)
Crimp tool: 57176-5000 (MOLEX)

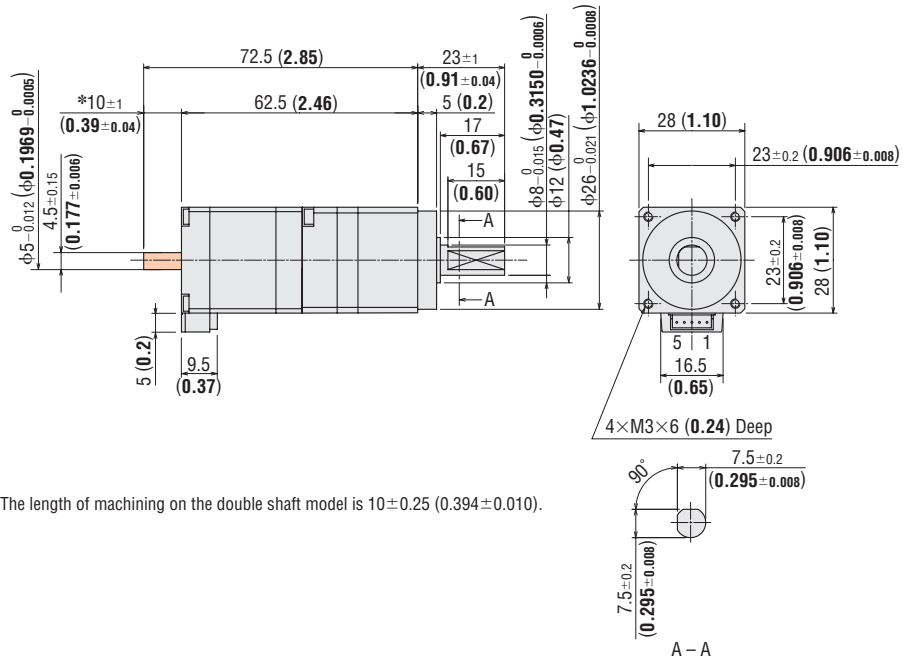

Motor Frame Size 42 mm (1.65 in.)

Model	Motor Model	Gear Ratio	Mass kg (lb.)	DXF
CRK544AP-N□	PK544AW-N□	5, 7.2, 10	0.56 (1.23)	B312
CRK544BP-N□	PK544BW-N□			

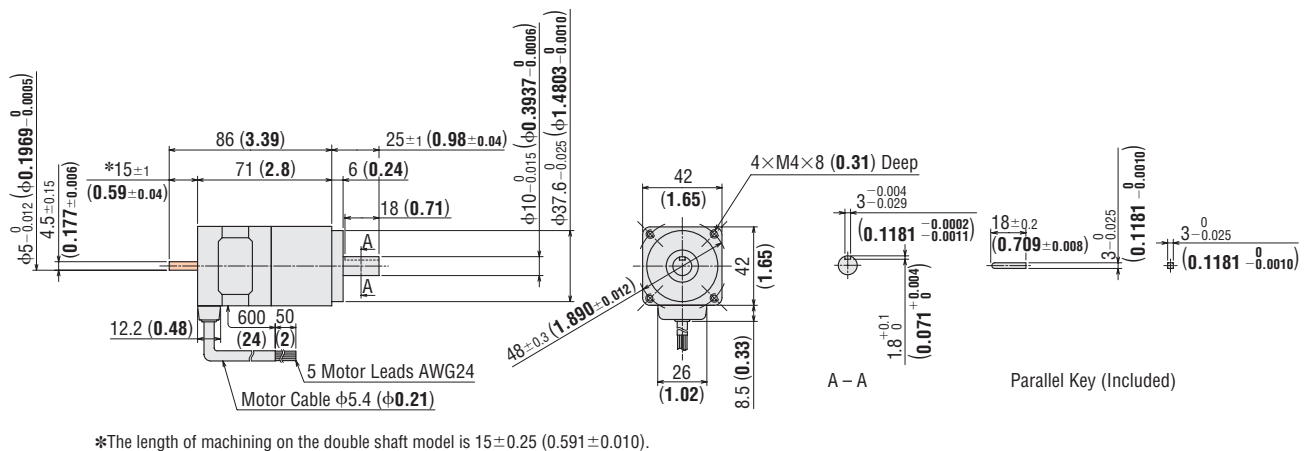

- A number indicating the gear ratio is entered where the box (□) is located within the product name.
- These dimensions are for the double shaft models. For the single shaft models, ignore the orange (■) areas.
- The dimensions of a motor with an encoder can be found on page A-19 or at www.orientalmotor.com.

Motor Frame Size 60 mm (2.36 in.)

Model	Motor Model	Gear Ratio	L1	L2	Mass kg (lb.)	DXF
Pulse Input Package						
CRK566AP-N □	PK566AW-N □	5, 7, 2, 10	103.5 (4.07)	—	1.5 (3.3)	B190
CRK566BP-N □	PK566BW-N □			124.5 (4.90)		
CRK564AP-N □	PK564AW-N □	25, 36, 50	108.5 (4.27)	—	1.5 (3.3)	B191
CRK564BP-N □	PK564BW-N □			129.5 (5.10)		

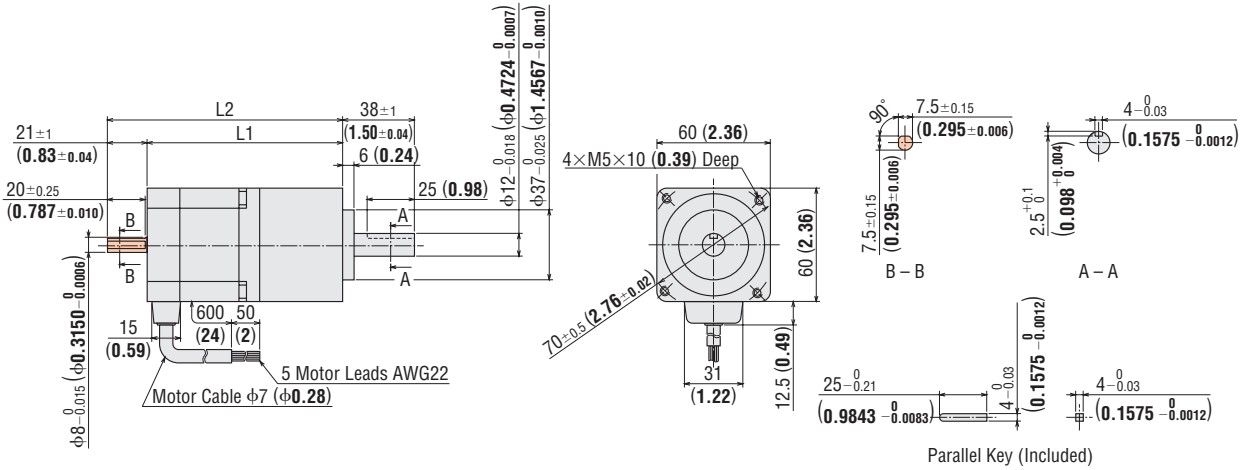

◇ Harmonic Geared Type

Motor Frame Size 20 mm (0.79 in.)

Model		Motor Model	Gear Ratio	Mass kg (lb.)	DXF
Pulse Input Package	Built-In Controller Package				
CRK513PAP-H □	CRK513PAKP-H □	PK513PA-H □ S	50, 100	0.08 (0.2)	B440
CRK513PBP-H □	CRK513PBKP-H □	PK513PB-H □ S			

Connection Cable of 0.6 m (2 ft.) is included with the package.

UL Style 3265, AWG24

If you are purchasing only a motor for maintenance purpose, etc., the connection cable and connector will not be supplied.

They must be purchased separately.

→ Page A-404

● Applicable Connector

Connector housing: 51065-0500 (MOLEX)

Contact: 50212-8100 (MOLEX)

Crimp tool: 57176-5000 (MOLEX)

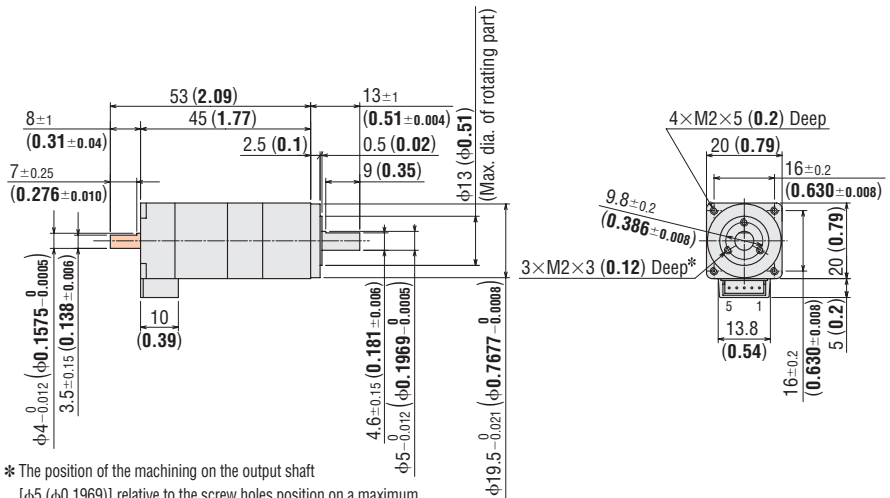

* The position of the machining on the output shaft [$\phi 5$ ($\phi 0.1969$)] relative to the screw holes position on a maximum diameter of $\phi 13$ ($\phi 0.51$) on the rotating part is arbitrary.

- A number indicating the gear ratio is entered where the box (□) is located within the product name.
- These dimensions are for the double shaft models. For the single shaft models, ignore the orange (■) areas.
- The dimensions of a motor with an encoder can be found on page A-19 or at www.orientalmotor.com.

Introduction	AC Input Motor & Driver	DC Input Motor & Driver
AR	0.36° / Geared	0.36° / Geared
AS	0.72° / Geared	0.36° / Geared
ASX	0.9° / 1.8°	0.36° / Geared
UMK	0.9° / 1.8°	0.36° / Geared
CRK	0.36° / Geared	0.36° / Geared
CMK	0.9° / 1.8° / Geared	0.36° / Geared
RBK	1.8° / Geared	0.36° / Geared
PK	0.36°	0.36°
PK	0.72°	0.72°
PK	0.9°	0.9°
PK/PV	1.8°	Motor Only
PK	Geared	Motor Only
SCX10 / EMP400 / 5G8030J	Controllers	Motor Only
	Accessories	Motor Only

Motor Frame Size 30 mm (1.18 in.)

Model		Motor Model	Gear Ratio	Mass kg (lb.)	DXF
Pulse Input Package	Built-In Controller Package				
CRK523PAP-H □	CRK523PAKP-H □	PK523HPA-H □ S	50, 100	0.2 (0.44)	B513
CRK523PBP-H □	CRK523PBKP-H □	PK523HPB-H □ S			

Connection Cable of 0.6 m (2 ft.) is included with the package.

UL Style 3265, AWG24

If you are purchasing only a motor for maintenance purpose, etc., the connection cable and connector will not be supplied.

They must be purchased separately.

→ Page A-404

● Applicable Connector

Connector housing: 51065-0500 (MOLEX)

Contact: 50212-8100 (MOLEX)

Crimp tool: 57176-5000 (MOLEX)

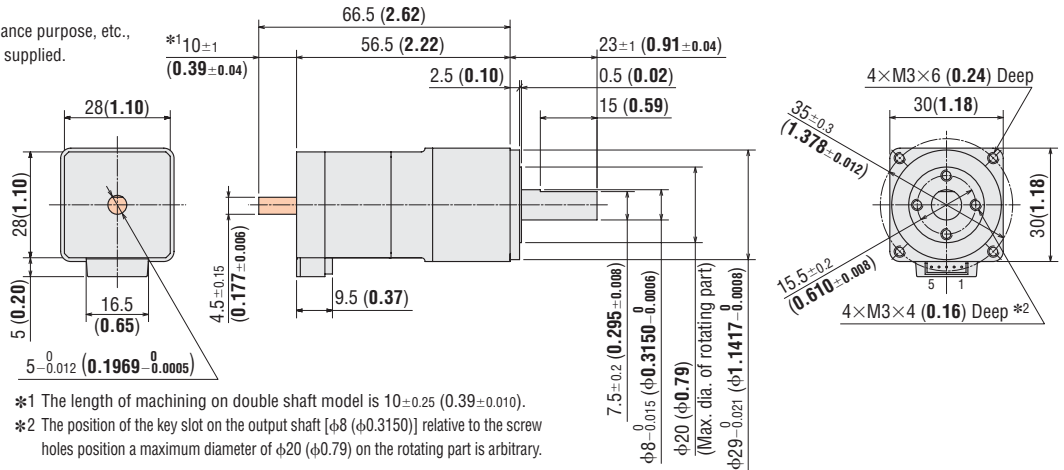

Motor Frame Size 42 mm (1.65 in.)

Model		Motor Model	Gear Ratio	Mass kg (lb.)	DXF
Pulse Input Package	Built-In Controller Package				
CRK543AP-H □	CRK543AKP-H □	PK543AW-H □ S	50, 100	0.46 (1.01)	B313
CRK543BP-H □	CRK543BKP-H □	PK543BW-H □ S			

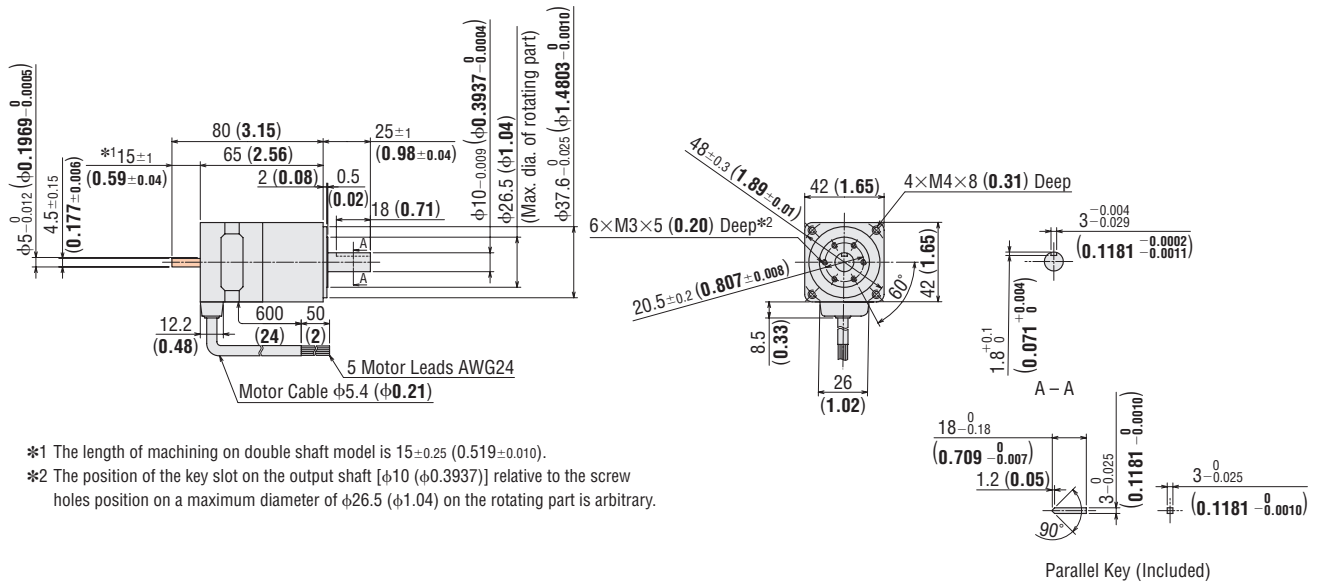

- A number indicating the gear ratio is entered where the box (□) is located within the product name.
- These dimensions are for the double shaft models. For the single shaft models, ignore the orange (■) areas.
- The dimensions of a motor with an encoder can be found on page A-19 or at www.orientalmotor.com.

Motor Frame Size 60 mm (2.36 in.)

Model		Motor Model	Gear Ratio	Mass kg (lb.)	DXF
Pulse Input Package	Built-In Controller Package				
CRK564AP-H □	CRK564AKP-H □	PK564AW-H □ S	50, 100	1.08 (2.4)	B314
CRK564BP-H □	CRK564BKP-H □	PK564BW-H □ S			

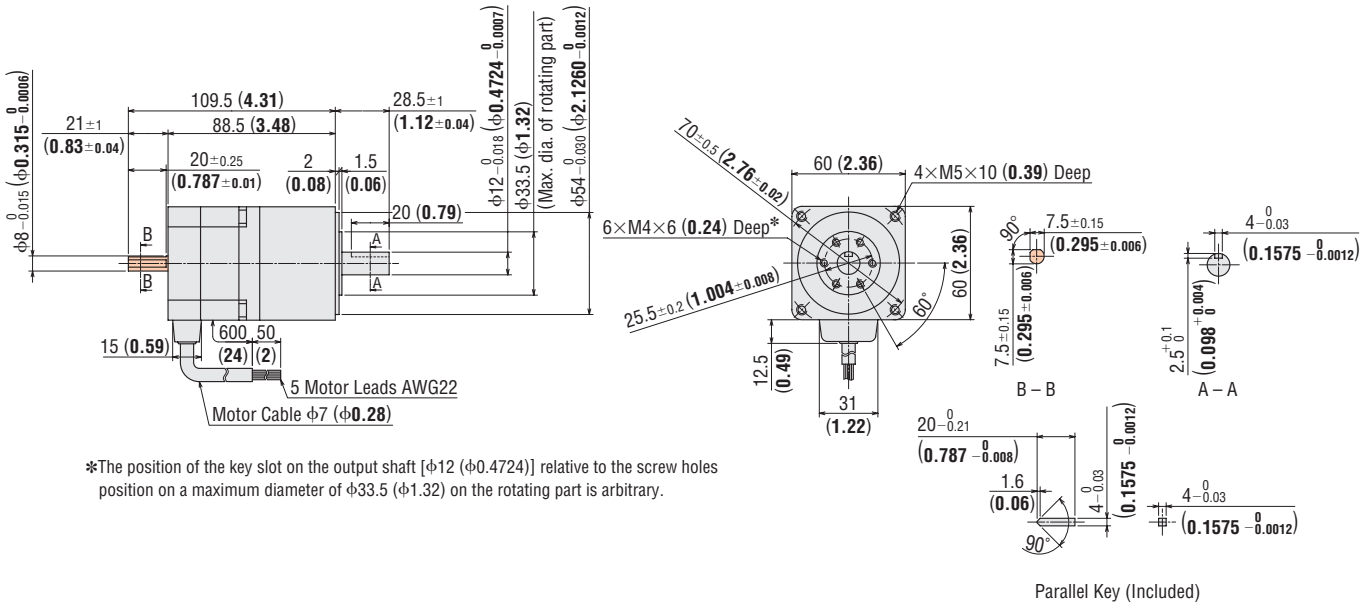

- A number indicating the gear ratio is entered where the box (□) is located within the product name.
- These dimensions are for the double shaft models. For the single shaft models, ignore the orange (■) areas.
- The dimensions of a motor with an encoder can be found on page A-19 or at www.orientalmotor.com.

● Driver

CRD5103P, CRD5107P, CRD5107HP, CRD5114P

Mass: 0.04 kg (0.09 lb.)

DXF B363

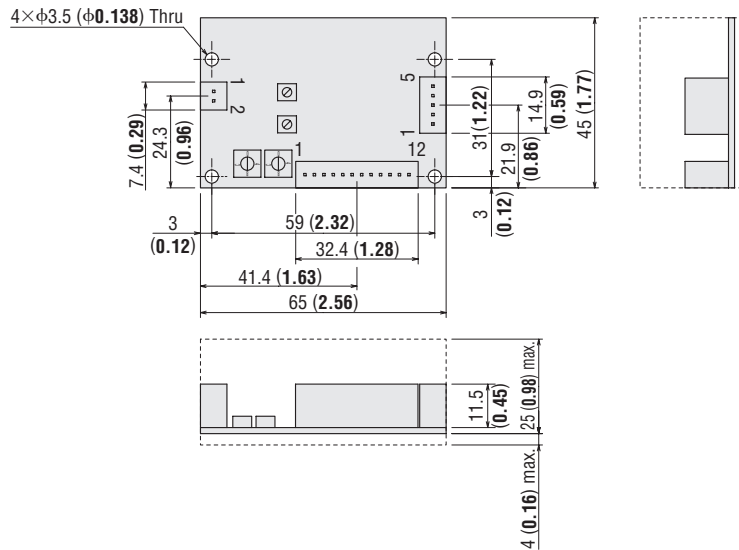

- Connector Housing (Included)
 - 51103-0200 (MOLEX)
 - 51103-1200 (MOLEX)
 - 51103-0500 (MOLEX)
- Contact (Included)
 - 50351-8100 (MOLEX)

Note

- Use the included connector for power supply, signal and motor. When assembling the connectors, use the hand-operated crimp tool [57295-5000 (MOLEX)]. The crimp tool is not included with the package. It must be purchased separately.
- Connection cable set crimped with connector is available (sold separately). → Page A-404

Introduction	AC Input Motor & Driver	DC Input Motor & Driver	Motor Only
AR	0.36° / Geared	0.36° / Geared	0.36°
AS	0.72° / Geared	0.9° / 1.8°	0.72°
ASX	0.9° / 1.8°	1.8° / Geared	0.9°
AR	0.36° / Geared	0.36° / Geared	1.8°
AS	0.72° / Geared	0.9° / 1.8°	PK
ASX	0.9° / 1.8°	1.8° / Geared	PK
CRK	0.36° / Geared	0.36° / Geared	PK
CMK	0.72° / Geared	0.9° / 1.8°	PK/PV
CMK	0.9° / 1.8°	1.8° / Geared	Geared
RBK	0.36° / Geared	0.36° / Geared	PK
PK	0.72° / Geared	0.9° / 1.8°	SCX10 / EMP400 / SG80301
PK	0.9° / 1.8°	1.8° / Geared	Accessories

CRD503-KP, CRD507-KP, CRD507H-KP, CRD514-KP

Mass: 0.2 kg (0.44 lb.)

DXF B547

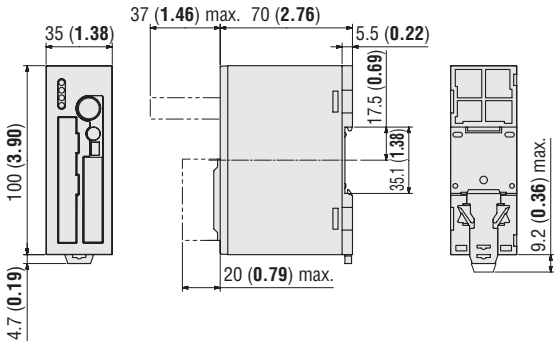

● Connector Housing and Contact (Included)

Power Input Terminal (CN1)

Connector: MC1,5/3-STF-3,5 (PHOENIX CONTACT)

Connection Cable for I/O Connector (CN2):

Connector: FX2B-40SA-1.27R (HIROSE ELECTRIC)

Connection Cable for Motor (CN4):

Connector Housing: 51103-0500 (MOLEX)

Contact: 50351-8100 (MOLEX)

Applicable Crimp Tool: 57295-5000 (MOLEX)

Connection Cable for Encoder (CN5)*

Connector Housing: 51106-0900 (MOLEX)

Contact: 50351-8000 (MOLEX)

Applicable Crimp Tool: 57295-5000 (MOLEX)

*Included with encoder motor only

● When you purchase only drivers for maintenance etc., it comes with power input terminal (CN1), connection cable for I/O connector (CN2) and connection cable for motor (CN4).

◇ Connection Cable for I/O Connector (CN2)

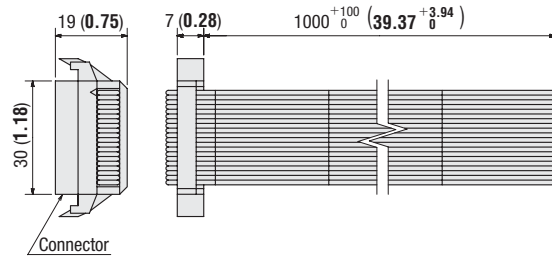

◇ Connection Cable for Motor (CN4)

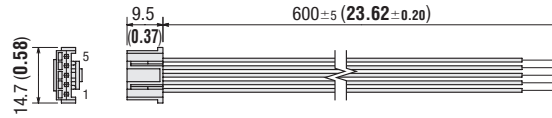

◇ Connection Cable for Encoder (CN5)

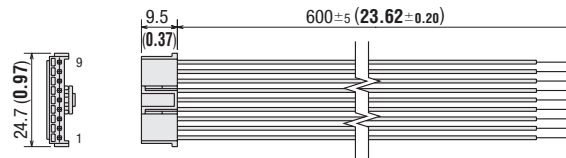

Connection and Operation

Names and Functions of Driver Parts

◇ Pulse Input Package

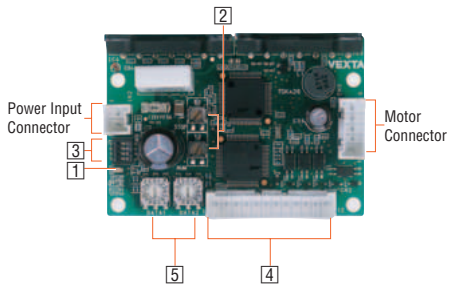

1 Power Input Display

Color	Function	When Activated
Green	Power supply indication	Lights when power is on.

2 Current Adjustment Potentiometers

Indication	Potentiometer Name	Function
RUN	Motor run current potentiometer	For adjusting the motor running current.
STOP	Motor stop current potentiometer	For adjusting the motor current at standstill.

3 Function Select Switches

Indication	Switch Name	Function
1P/2P	Pulse input mode switch	Switches between 1-pulse input and 2-pulse input.
OFF/SD	Smooth drive function switch	Enables or disables the smooth drive function.
R2/R1	Resolution select switch	Switches the basic step angle between R1 and R2.

4 Input/Output Signals

Indication	Input/Output	Pin No.	Signal Name	Function
CN2	Input	1	Pulse signal (CW pulse signal)	Operation command pulse signal (The motor will rotate in the CW direction when in 2-pulse input mode.)
		2		
		3	Rotation direction signal (CCW pulse signal)	Rotation direction signal Photocoupler ON: CW, Photocoupler OFF: CCW (The motor will rotate in the CCW direction when in 2-pulse input mode.)
		4		
		5	All windings off signal	Cuts the output current to the motor and allows the motor shafts can be rotated manually.
		6		
		7	Step angle select signal	Switches to step angle set in DATA1 and DATA2.
		8		
		9	Automatic current cutback release signal	This signal is used to disable the automatic current cutback function.
		10		
Output		11	Excitation timing signal	Outputs signals when the excitation sequence is at STEP "0".
		12		

Description of input/output signals → Page A-211

5 Step Angle Setting Switches

Indication	Switch Name	Function
DATA1	Step angle setting switch	Each switch can be set to the desired resolution from the 16 resolution levels.
DATA2		

R1				R2			
DATA1 DATA2	Microsteps/ Step 1	Resolution 1	Step Angle 1	DATA1 DATA2	Microsteps/ Step 2	Resolution 2	Step Angle 2
0	1	500	0.72°	0	×2.5	200	1.8°
1	2	1000	0.36°	1	×1.25	400	0.9°
2	2.5	1250	0.288°	2	1.6	800	0.45°
3	4	2000	0.18°	3	2	1000	0.36°
4	5	2500	0.144°	4	3.2	1600	0.225°
5	8	4000	0.09°	5	4	2000	0.18°
6	10	5000	0.072°	6	6.4	3200	0.1125°
7	20	10000	0.036°	7	10	5000	0.072°
8	25	12500	0.0288°	8	12.8	6400	0.05625°
9	40	20000	0.018°	9	20	10000	0.036°
A	50	25000	0.0144°	A	25.6	12800	0.028125°
B	80	40000	0.009°	B	40	20000	0.018°
C	100	50000	0.0072°	C	50	25000	0.0144°
D	125	62500	0.00576°	D	51.2	25600	0.0140625°
E	200	100000	0.0036°	E	100	50000	0.0072°
F	250	125000	0.00288°	F	102.4	51200	0.00703125°

Notes

- The step angle is calculated by dividing the basic step angle by the number of microstep. The above figures are based on a basic step angle of 0.72°.
- With the 0.36° high-torque type, the basic step angle and resolution are 0.36° and 1000 (microsteps/step 1), respectively.
- If you are using a geared type, the step angle divided by the gear ratio becomes the actual step angle.
- The number of microstep that can be switched by the "Step Angle Select" signal are limited to those selected in step angles 1 and 2.
- Do not change the "Step Angle Select" signal input or step angle setting switch while the motor is operating. It may cause the motor to misstep and stop.

◇ Built-In Controller Package

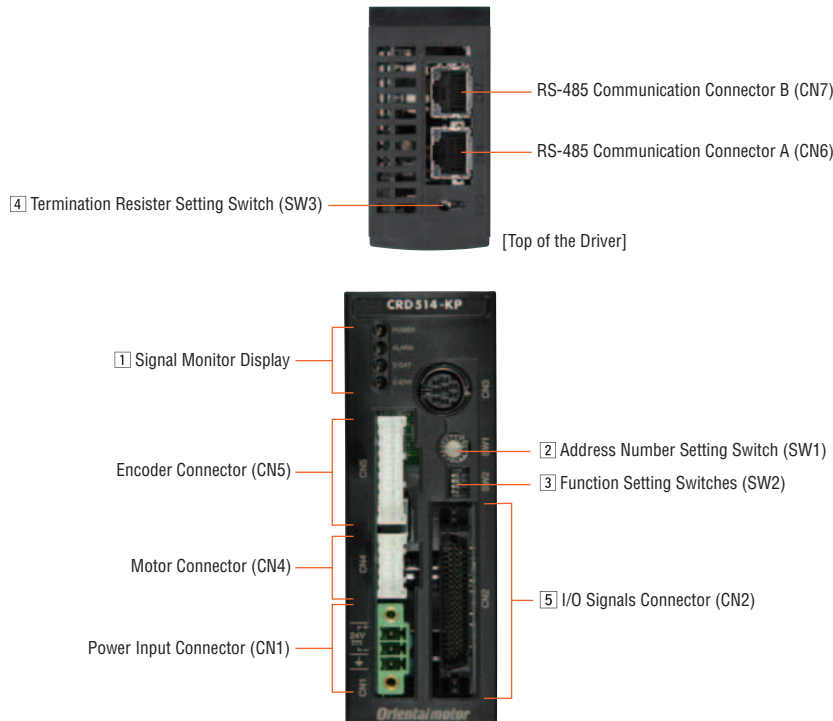

1 Signal Monitor Display

◇ LED Indicators

Indication	Color	Function	When Activated
POWER	Green	Power Supply Indication	Lights when power is on.
ALARM	Red	Alarm Indication	Blinks when protective functions are activated.
C-DAT	Green	Communication Indication	Blinks or illuminate when communication data is received or sent.
C-ERR	Red	Communication Error Indication	Illuminates when there is an error with communication data.

◇ Alarm

Blink Count	Function	When Activated
2	Overheat	The internal temperature of the driver has reached approximately 85°C (185°F).
3	Overvoltage	The primary voltage of the driver's inverter has exceeded the allowable level.
4	Over Position Error*	The deviation between the encoder counter value and command position reached the step out detection band when the "step out detection action" parameter was set to "alarm".
7	±LS Both Sides Active	Both the +LS and -LS signals were detected when LS detection was enabled.
	Reverse ±LS Connection	The LS opposite to the operating direction has detected during a return-to-home operation.
	Home Seeking Error	Return-to-home operation did not complete normally.
	No HOMES	The HOMES is not detected at a position between +LS and -LS during return-to-home operation in 3-sensor mode.
	TIM, Index, SLIT Input Error	None of the SLIT input, TIM output and Index output could be detected during return-to home operation.
	Hardware Over Travel	A +LS or -LS signal was detected when hardware over travel was enabled.
	Software Over Travel	A software limit was reached when software over travel was enabled.
9	Home Seeking Offset Error	A limit sensor signal was detected during offset movement as part of return-to-home operation.
	Invalid Operation Data	<ul style="list-style-type: none"> Five or more motions may be linked. Motion of different directions may be linked.
9	EEPROM Error	The stored data was damaged.

* Appropriate encoder has to be used with your motor

2 Address Number Setting Switch

Indication	Switch Name	Function
SW1	Address Number Setting Switch	Set the address number for RS-485 communication (Factory Setting: 0).

3 Function Setting Switches

Indication	SW2 No.	Function
SW2	1	Set the baud rate for RS-485 communications.
	2	
	3	
	4	Set device to signal or multi-axis mode.

◇ Setting the Baud Rate for RS-484 Communications

SW2 No.	Baud Rate	9600 bps	19200 bps	38400 bps	57600 bps	115200 bps			
	1	OFF	ON	OFF	ON	OFF	ON	OFF	ON
2	OFF	OFF	ON	ON	OFF	OFF	ON	ON	
3	OFF	OFF	OFF	OFF	OFF	ON	ON	ON	

◇ Setting the Multi-Axis Function for RS-484 Communications

SW2 No.	Switch Mode	Multi-Axis Mode
4	ON	Disabled
	OFF	Enabled

4 Termination Resister Setting Switches

Indication	Switch Name	Function
SW4	Termination Resister Setting Switches	Set the termination resister (120 Ω) for RS-485 communication. OFF: No termination resister ON: Set the termination resister

5 Input/Output Connector (CN2: 40 Pins)

Upper Ribbon Connection Cable (Input Signals)				Lower Ribbon Connection Cable (Output Signals)			
Lead Wire Color	Pin No.	Signal Name	Function	Lead Wire Color	Pin No.	Signal Name	Function
Brown-1	A1	IN-COM0	Input Common	Brown-3	B1	MOVE+	Motor Moving Output
Red-1	A2	START	Start Input	Red-3	B2	MOVE-	
Orange-1	A3	ALMCLR	Alarm Clear Input	Orange-3	B3	ALM+	Alarm Output
Yellow-1	A4	CROFF	Current OFF Input	Yellow-3	B4	ALM-	
Green-1	A5	ABORT	Abort Input	Green-3	B5	OUT1+	General Output 1*2
Blue-1	A6	IN1	General Inputs*1	Blue-3	B6	OUT1-	
Purple-1	A7	IN2		Purple-3	B7	OUT2+	General Output 2*2
Gray-1	A8	IN3		Gray-3	B8	OUT2-	
White-1	A9	IN4		White-3	B9	OUT3+	General Output 3*2
Black-1	A10	IN5		Black-3	B10	OUT3-	
Brown-2	A11	IN6		Brown-4	B11	OUT4+	General Output 4*2
Red-2	A12	HOME	Homing Operation Input	Red-4	B12	OUT4-	
Orange-2	A13	PSTOP	Panic Stop Input	Orange-4	B13	N.C.	Not Used
Yellow-2	A14	SENSOR	Sensor Input	Yellow-4	B14	N.C.	Not Used
Green-2	A15	+LS	+Limit Switch Input	Green-4	B15	PLS-OUT+	Pulse Output (Line Driver Output)
Blue-2	A16	-LS	-Limit Switch Input	Blue-4	B16	PLS-OUT-	
Purple-2	A17	HOMES	Home Sensor Input	Purple-4	B17	DIR-OUT+	Direction Output (Line Driver Output)
Gray-2	A18	SLIT	Slit Sensor Input	Gray-4	B18	DIR-OUT-	
White-2	A19	N.C.	Not Used	White-4	B19	GND	GND
Black-2	A20	IN-COM1	Sensor Input Common	Black-4	B20	N.C.	Not Used

*1 The function of General Input 1 (IN1) to 6 (IN6) can be assigned unique functions using the "INxxx" commands.

*2 The function of General Output 1 (OUT1) to 4 (OUT4) can be assigned unique functions using the "OUTxxx" commands.

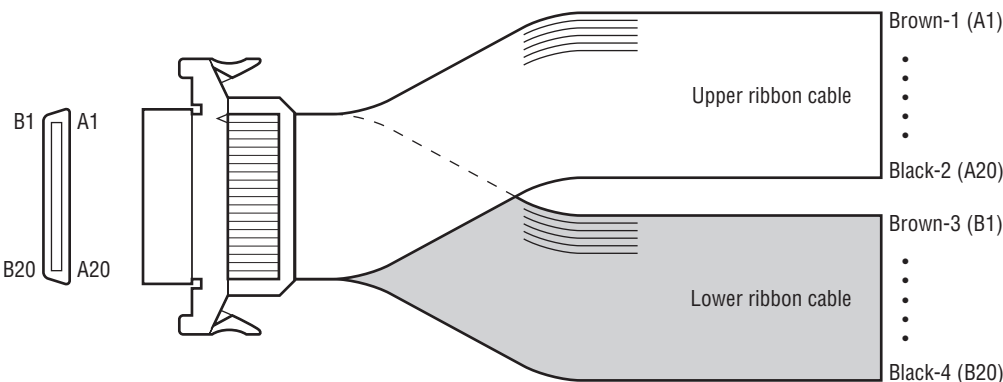

● Connection Diagram

◇ Pulse Input Package

● Connecting to a Current Sink Output Circuit

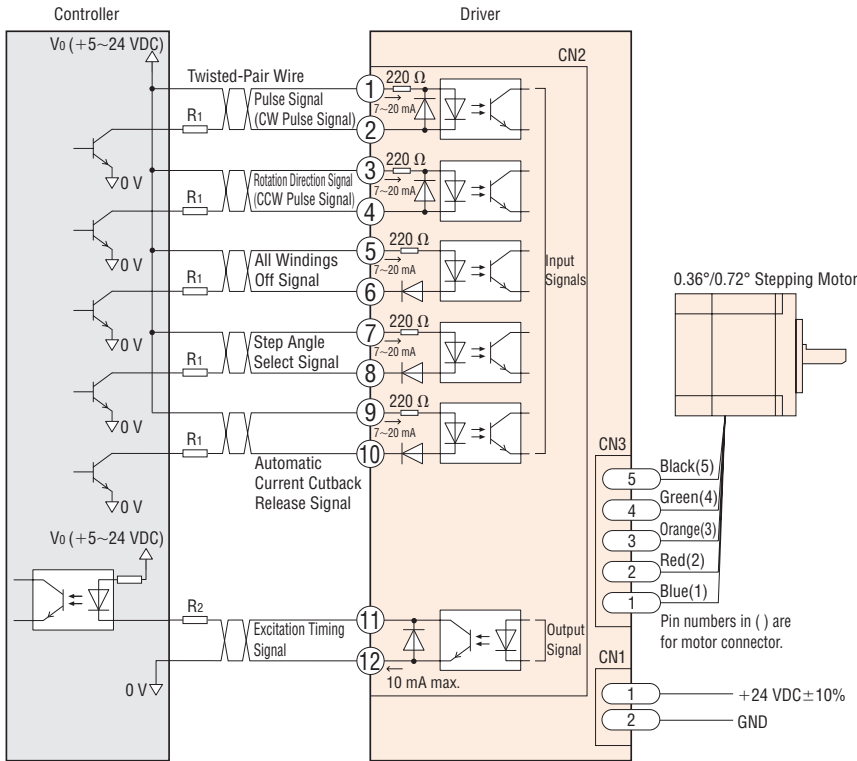

[Notes on Wiring]

◇ I/O Signal Connection

- Input Signal
Direct connection is possible when 5 VDC is applied. If a voltage exceeding 5 VDC is applied, connect an external resistor R_1 so that the current becomes 7 to 20 mA.
Example: When V_0 is 24 VDC, R_1 : 1.5 to 2.2 k Ω , 0.5 W min.
- Output Signal
Check the specifications of the connected device and if the current exceeds 10 mA, connect an external resistor R_2 .
- Use AWG24 to 22 twisted-pair wires.
- Since the maximum transmissible frequency drops as the pulse line becomes longer, keep the wiring length as short as possible [within 2 m (6.6 ft.)].
Technical reference → Page G-48
- Provide a distance of 100 mm (3.94 in.) min. between the I/O signal lines and power lines (power supply lines, motor lines, etc.).

◇ Power Supply Connection

- Use AWG22 wires.
- Incorrect polarities of the DC power-supply input will lead to driver damage.
Make sure that the polarity is correct before turning power on.

◇ Extension of Motor Cable

Use min. AWG22 wires.

◇ General

- A separate hand crimp tool is required to crimp the included connector and lead wire. The accessory connection cable set (sold separately) comes with all lead wires already crimped.
- If noise generated by the motor cable or power supply cable causes a problem with the specific wiring or layout, try shielding the cables or using ferrite cores.

● Connecting to a Current Source Output Circuit

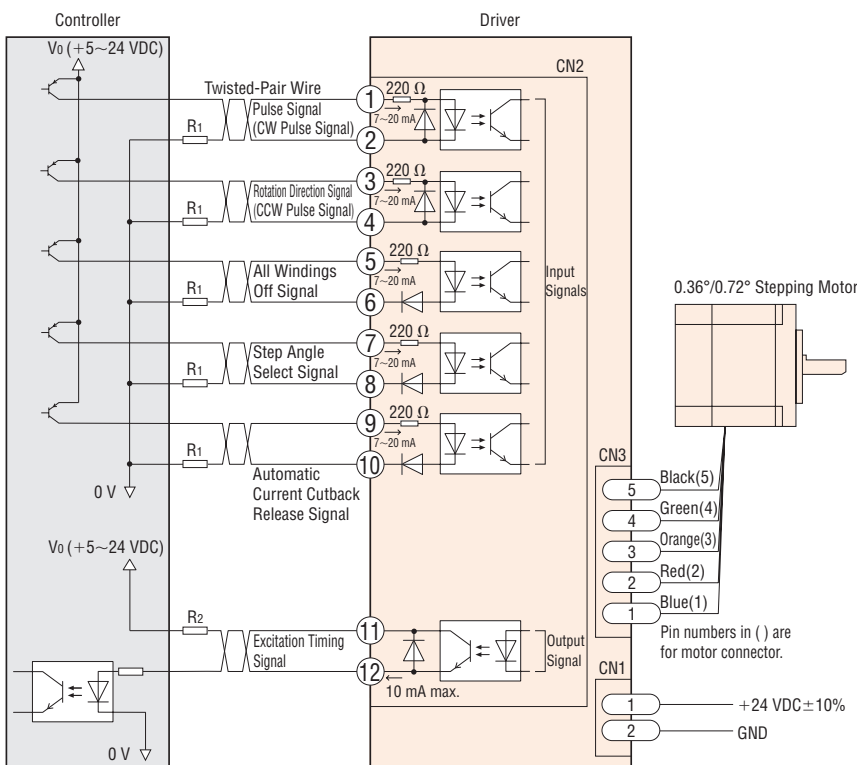

◆ Built-In Controller Package

● Connect to Other Devices

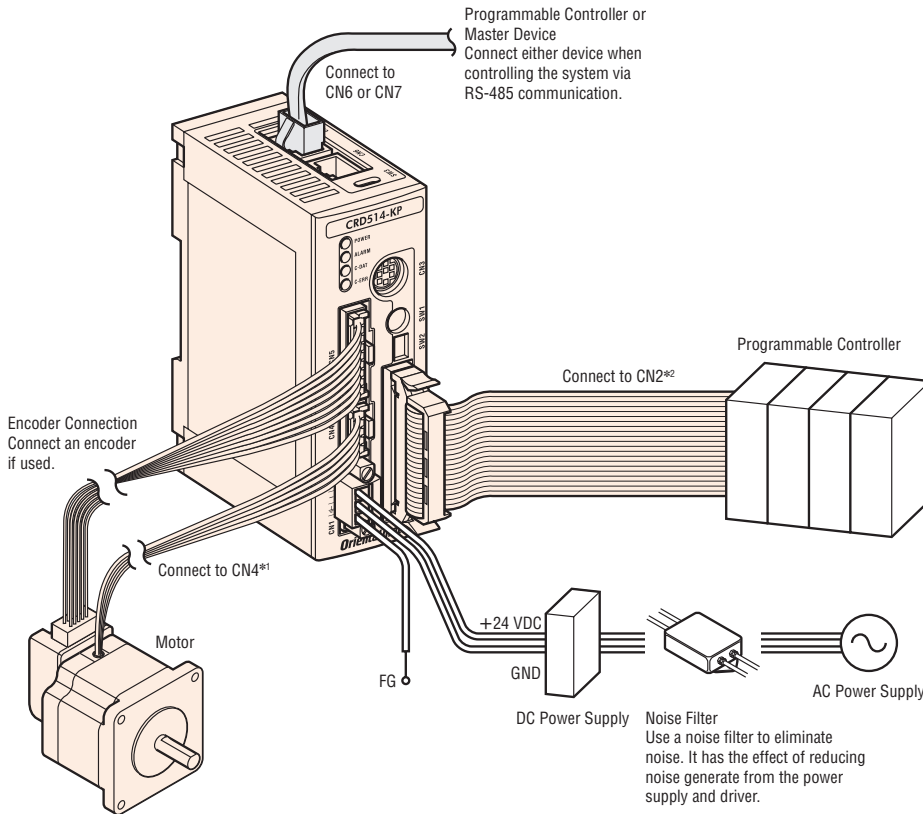

*1 If you are purchasing a package or only a driver, connection cable of 0.6 m (2 ft.) will be supplied.

*2 If you are purchasing a package or only a driver, connection cable of 1 m (3.3 ft.) will be supplied.

◆ Power Supply Connection

Use the CN1 connector (included) to connect the power supply cable to the power supply connector (CN1) on the driver. Incorrect connection of DC power input will lead to driver damage.

Make sure that the polarity is correct before turning power on.

Use a power supply that can supply sufficient input current.

When power supply capacity is insufficient, a decrease in motor output can cause the following malfunctions:

- Motor does not operate properly at high-speed
- Slow motor startup and stopping

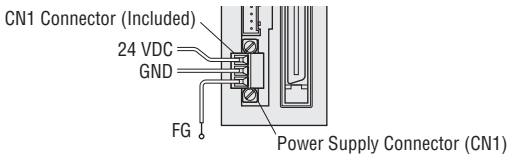

◆ Motor Connection

Connect the connection cable for CN4 (included) into the motor connector (CN4) on the driver. Next, connect the motor leads and the CN4 cable leads. The customer must provide a suitable terminal block, connectors and other items needed to interconnect the leads.

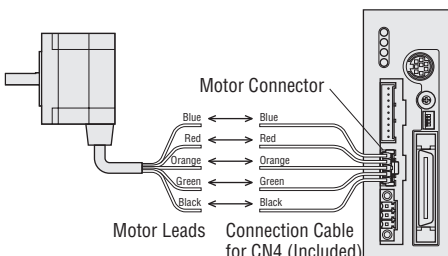

◆ Encoder Connection

Use the CN1 connector (Included) to connect to the encoder connector (CN5) on the driver.

● Example of Standard Type with Encoder

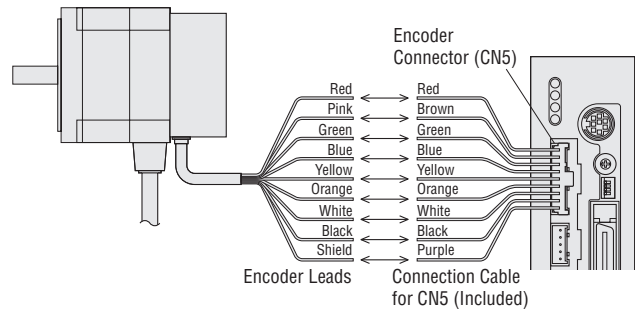

● Connector CN5

Pin No.	Signal Name	Description	Encoder Lead Wire Color
1	ENC-A+	Encoder Input A-Channel	Red
2	ENC-A-	(Line Receiver)	Pink
3	ENC-B+	Encoder Input B-Channel	Green
4	ENC-B-	(Line Receiver)	Blue
5	ENC-I+	Encoder Input Index Signal	Yellow
6	ENC-I-	(Line Receiver)	Orange
7	+5 VDC OUT	+5 VDC Power Supply for Output for Encoder	White
8	GND	GND	Black
9	SHIELD	Shield (Connect to GND)	Shield

Introduction	
AR	AC Input Motor & Driver
AS	0.36° / Geared
ASX	0.36° / Geared
CRK	0.72° / Geared
CMK	0.9° / 1.8° / Geared
RBK	1.8° / Geared
PK	0.36°
PK	0.72°
PK	0.9°
PK/PV	1.8°
PK	Geared
SCX10 / EMP400 / SG8030J	Controllers
	Accessories

• Connecting to a Current Sink Output Circuit

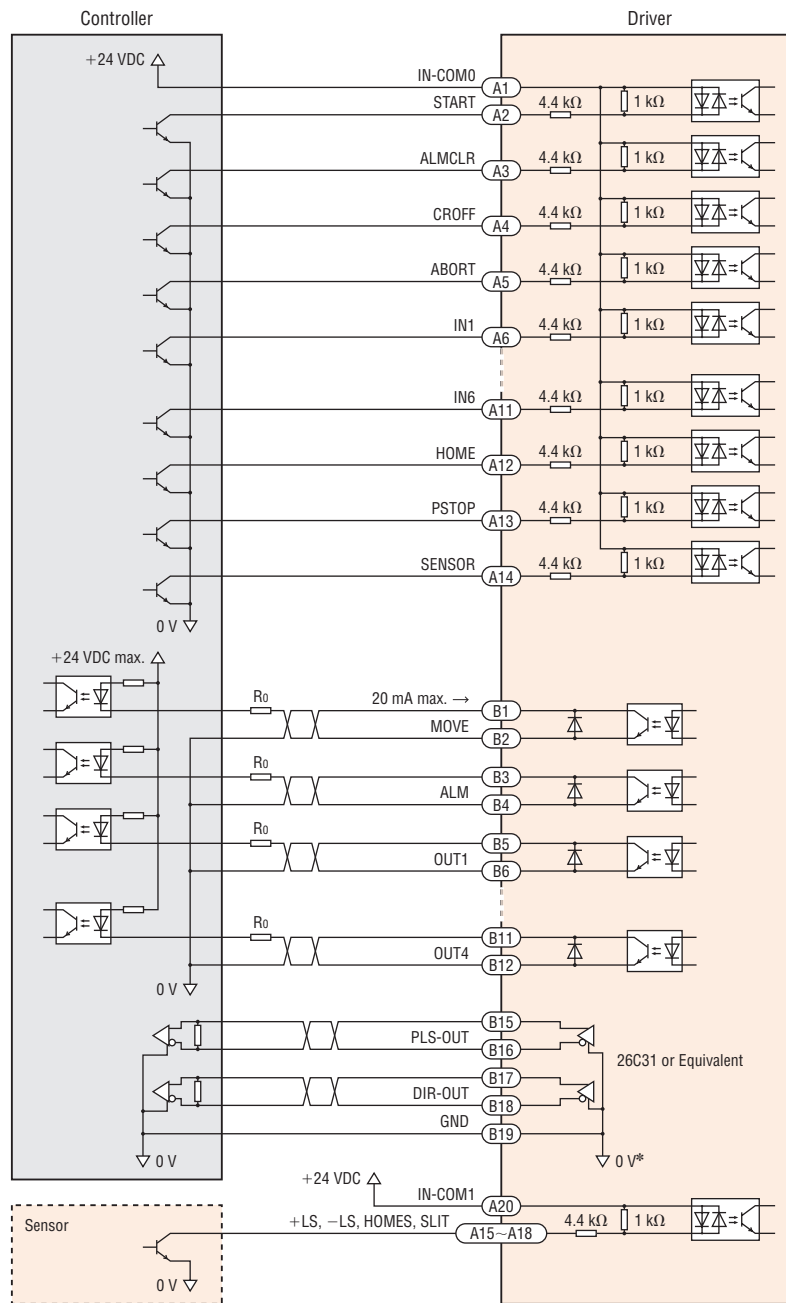

* The GND line is used in common with CN1 (not insulated)

Notes

- Use the included connection cable as the I/O signal cable and keep it as short as possible.
- Use 24 VDC for the input signal. The internal components may be damaged if the specifications are exceeded.
- Use 24 VDC or less for the output signal, and 20 mA or less for the current. The internal components may be damaged if the specifications are exceeded. Check the specifications of the connected device, and if the current exceeds 20 mA, connect an external resistor R_0 .
- Connect a terminal resistor of 100 Ω or more between the input of the line receiver terminals.
- Signal lines should be kept at least 100 mm (3.94 in.) away from power lines (power supply lines and motor lines). Do not run the signal lines in the same duct or bundle them together.
- If noise generated by the motor cables or power supply cables causes a problem, try shielding the cables or using ferrite cores.

• Connecting to a Current Source Output Circuit

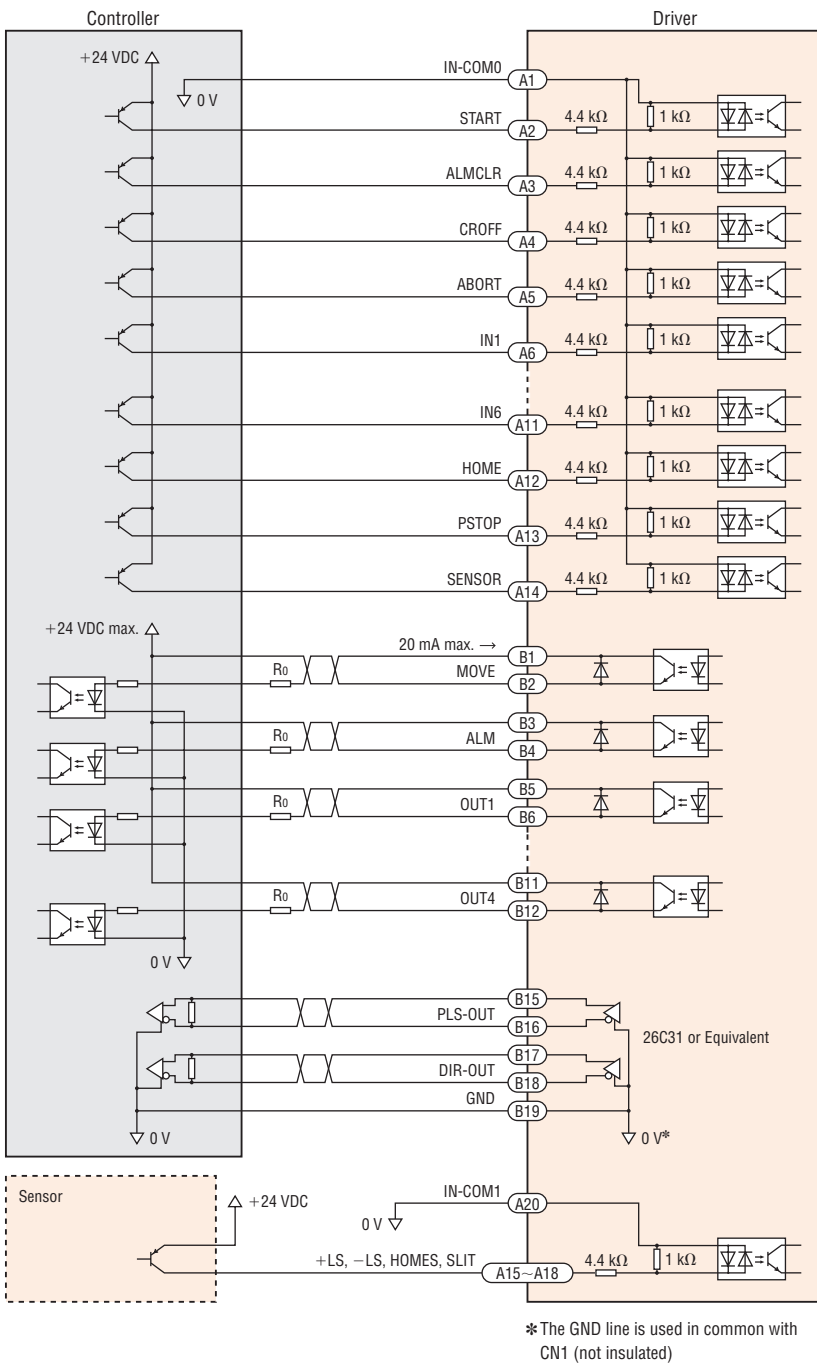

*The GND line is used in common with CN1 (not insulated)

Notes

- Use the included connection cable as the I/O signal cable and keep it as short as possible.
- Use 24 VDC for the input signal. The internal components may be damaged if the specifications are exceeded.
- Use 24 VDC or less for the output signal, and 20 mA or less for the current. The internal components may be damaged if the specifications are exceeded. Check the specifications of the connected device, and if the current exceeds 20 mA, connect an external resistor R_0 .
- Connect a terminal resistor of 100 Ω or more between the input of the line receiver terminals.
- Signal lines should be kept at least 100 mm (3.94 in.) away from power lines (power supply lines and motor lines). Do not run the signal lines in the same duct or bundle them together.
- If noise generated by the motor cables or power supply cables causes a problem, try shielding the cables or using ferrite cores.

Introduction	AC Input Motor & Driver
AR	0.36° / Geared
AS	0.72° / Geared
UMK	0.9°/1.8°
AR	0.36° / Geared
ASX	0.36° / Geared
CRK	0.36°/0.72° / Geared
CMK	0.9°/1.8° / Geared
RBK	1.8° / Geared
PK	0.36°
PK	0.72°
PK	0.9°
PK/PV	1.8°
PK	Geared
Controllers	SCX10 / EMP400 / 5G8030J
Accessories	

List of Motor and Driver Combinations

Model names for motor and driver combinations are shown below.

Pulse Input Packages

Without Encoders

Type	Model	Motor Model	Driver Model
Step Angle 0.36° High-Torque Type	CRK523P □P CRK524P □P CRK525P □P	PK523P□* PK524P□* PK525P□*	CRD5103P
	CRK544P □P CRK546P □P	PK544P□* PK546P□*	CRD5107P
	CRK564P □P CRK566P □P CRK569P □P	PK564P□* PK566P□* PK569P□*	CRD5114P
	CRK513P □P	PK513P□*	
Step Angle 0.72° High-Torque Type	CRK523P □P CRK525P □P	PK523P□* PK525P□*	CRD5103P
	CRK544P □P CRK546P □P	PK544P□* PK546P□*	
	CRK543 □P CRK544 □P CRK545 □P	PK543N□W PK544N□W PK545N□W	CRD5107P
Step Angle 0.72° Standard Type	CRK564 □P CRK566 □P CRK569 □P	PK564N□W PK566N□W PK569N□W	CRD5114P
	CRK523P □P-T7.2 CRK523P □P-T10 CRK523P □P-T20 CRK523P □P-T30	PK523P□-T7.2* PK523P□-T10* PK523P□-T20* PK523P□-T30*	CRD5103P
	CRK543 □P-T3.6 CRK543 □P-T7.2 CRK543 □P-T10 CRK543 □P-T20 CRK543 □P-T30	PK543□W-T3.6 PK543□W-T7.2 PK543□W-T10 PK543□W-T20 PK543□W-T30	CRD5107P
TH Geared Type	CRK564 □P-T3.6 CRK564 □P-T7.2 CRK564 □P-T10 CRK564 □P-T20 CRK564 □P-T30	PK564□W-T3.6 PK564□W-T7.2 PK564□W-T10 PK564□W-T20 PK564□W-T30	CRD5114P

Type	Model	Motor Model	Driver Model
PS Geared Type	CRK523P □P-PS5 CRK523P □P-PS7 CRK523P □P-PS10	PK523P□-PS5* PK523P□-PS7* PK523P□-PS10*	CRD5103P
	CRK545 □P-PS5 CRK545 □P-PS7 CRK545 □P-PS10 CRK543 □P-PS25 CRK543 □P-PS36 CRK543 □P-PS50	PK545□W-PS5 PK545□W-PS7 PK545□W-PS10 PK543□W-PS25 PK543□W-PS36 PK543□W-PS50	CRD5107P
	CRK566 □P-PS5 CRK566 □P-PS7 CRK566 □P-PS10 CRK564 □P-PS25 CRK564 □P-PS36 CRK564 □P-PS50	PK566□W-PS5 PK566□W-PS7 PK566□W-PS10 PK564□W-PS25 PK564□W-PS36 PK564□W-PS50	CRD5114P
	CRK523P □P-N5 CRK523P □P-N7.2 CRK523P □P-N10	PK523P□-N5* PK523P□-N7.2* PK523P□-N10*	CRD5103P
	CRK544 □P-N5 CRK544 □P-N7.2 CRK544 □P-N10	PK544□W-N5 PK544□W-N7.2 PK544□W-N10	CRD5107P
	CRK566 □P-N5 CRK566 □P-N7.2 CRK566 □P-N10 CRK564 □P-N25 CRK564 □P-N36 CRK564 □P-N50	PK566□W-N5 PK566□W-N7.2 PK566□W-N10 PK564□W-N25 PK564□W-N36 PK564□W-N50	CRD5114P
	CRK513P □P-H50 CRK513P □P-H100	PK513P□-H50S* PK513P□-H100S*	CRD5103P
	CRK523P □P-H50 CRK523P □P-H100	PK523HP□-H50S* PK523HP□-H100S*	CRD5107HP
	CRK543 □P-H50 CRK543 □P-H100	PK543□W-H50S PK543□W-H100S	CRD5107P
	CRK564 □P-H50 CRK564 □P-H100	PK564□W-H50S PK564□W-H100S	CRD5114P

● Enter **A** (single shaft) or **B** (double shaft) in the box (□) within the model name.

* If you are purchasing only a motor for maintenance purpose, etc., the connection cable will not be supplied. They must be purchased separately. They are available as accessories.
Connection Cable → Page A-404

With Encoders

Type	Model	Motor Model	Driver Model
Step Angle 0.36° High-Torque Type with Encoder	CRK544P MAP-R28 CRK546P MAP-R28 CRK564P MAP-R28 CRK566P MAP-R28 CRK569P MAP-R28	PK544PMA-R28* PK546PMA-R28* PK564PMA-R28* PK566PMA-R28* PK569PMA-R28*	CRD5107P CRD5114P
	CRK544P AP-R27 CRK546P AP-R27	PK544PA-R27* PK546PA-R27*	CRD5107P
	CRK543AP -R27 CRK544AP -R27 CRK545AP -R27	PK543NAW-R27 PK544NAW-R27 PK545NAW-R27	CRD5107P
	CRK564AP -R27 CRK566AP -R27 CRK569AP -R27	PK564NAW-R27 PK566NAW-R27 PK569NAW-R27	CRD5114P
TH Geared Type with Encoder	CRK543APR 27T3.6 CRK543APR 27T7.2 CRK543APR 27T10 CRK543APR 27T20 CRK543APR 27T30	PK543AWR27T3.6 PK543AWR27T7.2 PK543AWR27T10 PK543AWR27T20 PK543AWR27T30	CRD5107P
	CRK564APR 27T3.6 CRK564APR 27T7.2 CRK564APR 27T10 CRK564APR 27T20 CRK564APR 27T30	PK564AWR27T3.6 PK564AWR27T7.2 PK564AWR27T10 PK564AWR27T20 PK564AWR27T30	CRD5114P

Type	Model	Motor Model	Driver Model
PS Geared Type with Encoder	CRK545APR 27PS5 CRK545APR 27PS7 CRK545APR 27PS10 CRK543APR 27PS25 CRK543APR 27PS36 CRK543APR 27PS50	PK545AWR27PS5 PK545AWR27PS7 PK545AWR27PS10 PK543AWR27PS25 PK543AWR27PS36 PK543AWR27PS50	CRD5107P
	CRK566APR 27PS5 CRK566APR 27PS7 CRK566APR 27PS10 CRK564APR 27PS25 CRK564APR 27PS36 CRK564APR 27PS50	PK566AWR27PS5 PK566AWR27PS7 PK566AWR27PS10 PK564AWR27PS25 PK564AWR27PS36 PK564AWR27PS50	CRD5114P
	CRK543APR 27H50 CRK543APR 27H100	PK543AWR27H50 PK543AWR27H100	CRD5107P
	CRK564APR 27H50 CRK564APR 27H100	PK564AWR27H50 PK564AWR27H100	CRD5114P

● If you are purchasing only a motor for maintenance purpose, etc., the encoder connection cable will not be supplied. They must be purchased separately. They are available as accessories.

* If you are purchasing only a motor for maintenance purpose, etc., the connection cable will not be supplied. They must be purchased separately. They are available as accessories.
Connection Cable → Page A-404

Encoder Connection Cable → Page A-405

● Built-In Controller Packages

◇ Without Encoder

Type	Model	Motor Model	Driver Model
Step Angle 0.36° High-Torque Type	CRK523PM □ KP	PK523PM□*	CRD503-KP
	CRK524PM □ KP	PK524PM□*	
	CRK525PM □ KP	PK525PM□*	
	CRK544PM □ KP	PK544PM□*	CRD507-KP
	CRK546PM □ KP	PK546PM□*	
	CRK564PM □ KP	PK564PM□*	
Step Angle 0.72° High-Torque Type	CRK566PM □ KP	PK566PM□*	CRD514-KP
	CRK569PM □ KP	PK569PM□*	
	CRK513P □ KP	PK513P□*	
	CRK523P □ KP	PK523P□*	CRD503-KP
	CRK525P □ KP	PK525P□*	
	CRK544P □ KP	PK544P□*	
Step Angle 0.72° Standard Type	CRK546P □ KP	PK546P□*	CRD507-KP
	CRK543 □ KP	PK543N□W	
	CRK544 □ KP	PK544N□W	
	CRK545 □ KP	PK545N□W	CRD514-KP
	CRK564 □ KP	PK564N□W	
	CRK566 □ KP	PK566N□W	
TH Geared Type	CRK523P □ KP-T7.2	PK523P□-T7.2*	CRD503-KP
	CRK523P □ KP-T10	PK523P□-T10*	
	CRK523P □ KP-T20	PK523P□-T20*	
	CRK523P □ KP-T30	PK523P□-T30*	
	CRK543 □ KP-T3.6	PK543□W-T3.6	CRD507-KP
	CRK543 □ KP-T7.2	PK543□W-T7.2	
	CRK543 □ KP-T10	PK543□W-T10	
	CRK543 □ KP-T20	PK543□W-T20	
	CRK543 □ KP-T30	PK543□W-T30	CRD514-KP
	CRK564 □ KP-T3.6	PK564□W-T3.6	
	CRK564 □ KP-T7.2	PK564□W-T7.2	
	CRK564 □ KP-T10	PK564□W-T10	
CRK564 □ KP-T20	PK564□W-T20		
CRK564 □ KP-T30	PK564□W-T30		

◇ With Encoder

Type	Model	Motor Model	Driver Model
Step Angle 0.36° High-Torque Type with Encoder	CRK544PMRKP	PK544PMA-R28L*	CRD507-KP
	CRK546PMRKP	PK546PMA-R28L*	
	CRK564PMRKP	PK564PMA-R28L*	CRD514-KP
	CRK569PMRKP	PK569PMA-R28L*	
Step Angle 0.72° High-Torque Type with Encoder	CRK544PRKP	PK544PA-R27L*	CRD507-KP
	CRK546PRKP	PK546PA-R27L*	
Step Angle 0.72° Standard Type with Encoder	CRK543RKP	PK543NAW-R27L	CRD507-KP
	CRK544RKP	PK544NAW-R27L	
	CRK545RKP	PK545NAW-R27L	
	CRK564RKP	PK564NAW-R27L	CRD514-KP
	CRK566RKP	PK566NAW-R27L	
	CRK569RKP	PK569NAW-R27L	
TH Geared Type with Encoder	CRK543RKPT3.6	PK543AWR27LT3.6	CRD507-KP
	CRK543RKPT7.2	PK543AWR27LT7.2	
	CRK543RKPT10	PK543AWR27LT10	
	CRK543RKPT20	PK543AWR27LT20	
	CRK543RKPT30	PK543AWR27LT30	CRD514-KP
	CRK564RKPT3.6	PK564AWR27LT3.6	
	CRK564RKPT7.2	PK564AWR27LT7.2	
	CRK564RKPT10	PK564AWR27LT10	
	CRK564RKPT20	PK564AWR27LT20	
	CRK564RKPT30	PK564AWR27LT30	

Type	Model	Motor Model	Driver Model
PS Geared Type	CRK523P □ KP-PS5	PK523P□-PS5*	CRD503-KP
	CRK523P □ KP-PS7	PK523P□-PS7*	
	CRK523P □ KP-PS10	PK523P□-PS10*	
	CRK545 □ KP-PS5	PK545□W-PS5	CRD507-KP
	CRK545 □ KP-PS7	PK545□W-PS7	
	CRK545 □ KP-PS10	PK545□W-PS10	
	CRK543 □ KP-PS25	PK543□W-PS25	
	CRK543 □ KP-PS36	PK543□W-PS36	
	CRK543 □ KP-PS50	PK543□W-PS50	
	CRK566 □ KP-PS5	PK566□W-PS5	CRD514-KP
	CRK566 □ KP-PS7	PK566□W-PS7	
	CRK566 □ KP-PS10	PK566□W-PS10	
CRK564 □ KP-PS25	PK564□W-PS25		
CRK564 □ KP-PS36	PK564□W-PS36		
CRK564 □ KP-PS50	PK564□W-PS50		
Harmonic Geared Type	CRK513P □ KP-H50	PK513P□-H50S*	CRD503-KP
	CRK513P □ KP-H100	PK513P□-H100S*	CRD507H-KP
	CRK523P □ KP-H50	PK523HP□-H50S*	CRD507H-KP
	CRK523P □ KP-H100	PK523HP□-H100S*	
	CRK543 □ KP-H50	PK543□W-H50S	CRD507-KP
	CRK543 □ KP-H100	PK543□W-H100S	
	CRK564 □ KP-H50	PK564□W-H50S	CRD514-KP
	CRK564 □ KP-H100	PK564□W-H100S	

● Enter **A** (single shaft) or **B** (double shaft) in the box (□) within the model name.

* If you are purchasing only a motor for maintenance purpose, etc., the connection cable will not be supplied. They must be purchased separately. They are available as accessories.
Connection Cable → Page A-405

Type	Model	Motor Model	Driver Model
PS Geared Type with Encoder	CRK545RKPP55	PK545AWR27LPS5	CRD507-KP
	CRK545RKPP57	PK545AWR27LPS7	
	CRK545RKPP10	PK545AWR27LPS10	
	CRK543RKPP25	PK543AWR27LPS25	
	CRK543RKPP36	PK543AWR27LPS36	
	CRK543RKPP50	PK543AWR27LPS50	
	CRK566RKPP55	PK566AWR27LPS5	CRD514-KP
	CRK566RKPP57	PK566AWR27LPS7	
	CRK566RKPP10	PK566AWR27LPS10	
	CRK564RKPP25	PK564AWR27LPS25	
	CRK564RKPP36	PK564AWR27LPS36	
	CRK564RKPP50	PK564AWR27LPS50	
Harmonic Geared Type with Encoder	CRK543RKPH50	PK543AWR27LH50	CRD507-KP
	CRK543RKPH100	PK543AWR27LH100	CRD514-KP
	CRK564RKPH50	PK564AWR27LH50	
	CRK564RKPH100	PK564AWR27LH100	

● Enter **A** (single shaft) or **B** (double shaft) in the box (□) within the model name.

● If you are purchasing only a motor for maintenance purpose, etc., the encoder connection cable will not be supplied. They must be purchased separately. They are available as accessories.

* If you are purchasing only a motor for maintenance purpose, etc., the connection cable will not be supplied. They must be purchased separately. They are available as accessories.
Connection Cable → Page A-405

Encoder Connection Cable → Page A-405